



SECTION 1

BENDIX

Si vous détectez des  **erreurs** dans ce catalogue, s'il-vous-plaît, nous en aviser

Nous désirons que les informations soient le plus précises possible.
Nous apprécions votre aide à ce sujet.

Veuillez nous contacter par courriel pour tous
commentaires / suggestions et/ou corrections à :
admin@atelierjp.ca

SECTION 1

BENDIX

Governors / Gouverneurs.....	1-1
Quick release & limiting valve / Soupapes d'échappement rapide et de limitation.....	1-2
Check valves / Soupapes unidirectionnelles.....	1-5
Safety valves / Soupapes de sûreté.....	1-6
Ratio & proportioning valves / Soupapes de dosage pour frein à air.....	1-8
Protection & pressure reducing valves / Soupapes de protection.....	1-10
Foot operated valves / Soupapes clapet de pied.....	1-13
Relay & relay emergency valves / Soupapes de relais et relais d'urgence.....	1-17
Control valves / Soupapes de contrôle.....	1-23
Shut off & synchronizing valves / Soupapes de coupure et de synchronisation.....	1-33
Inversion valves / Soupapes d'inversion.....	1-34
Spring brake valves / Soupapes de frein ressort.....	1-35
Indicating & warning devices / Indicateurs et avertisseurs d'urgence.....	1-38
Drain valves / Soupapes de drainage.....	1-41

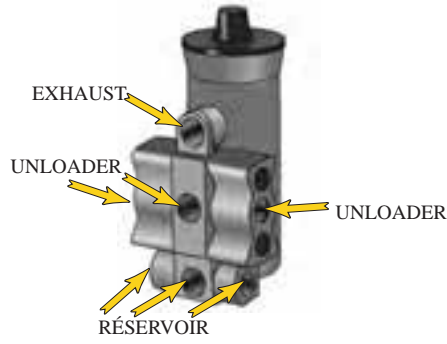

- **D - 2 Governor.**
- Weight 1 lb.

SERVICE#	RESERVOIR	UNLOADER	EXHAUST	PRESSURE RANGE	NOTES
275200	3-1/8" PT	3-1/8" PT	1/8" PT	90 - 105 PSI	
275491	3-1/8" PT	3-1/8" PT	1/8" PT	100 - 120 PSI	
275508	3-1/8" PT	3-1/8" PT	1/8" PT	95 - 110 PSI	
275530	3-1/8" PT	3-1/8" PT	1/8" PT	105 - 125 PSI	
275707	3-1/8" PT	3-1/8" PT	1/8" PT	105 - 125 PSI	
277486	3-1/8" PT	3-1/8" PT	1/8" PT	110 - 130 PSI	
283657	3-1/8" PT	3-1/8" PT	1/8" PT	115 - 135 PSI	
284358	3-1/8" PT	3-1/8" PT	1/8" PT	105 - 125 PSI	High Temp, O-Rings and Waterproof Cover
5004049	3-1/8" PT	3-1/8" PT	1/8" PT	105 - 130 PSI	Use in conjunction with AD-1S Air Dryer
800361	3-1/8" PT	3-1/8" PT	1/8" PT	105 - 130 PSI	Non-adjustable

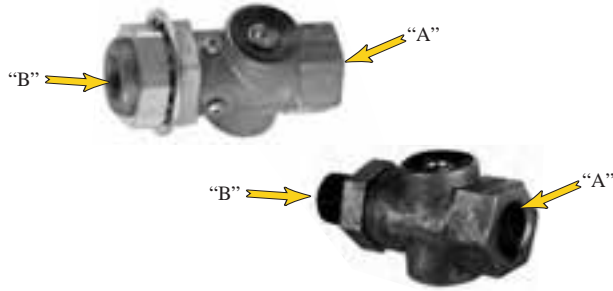

• QR-L Inline Quick Release Valve.

SERVICE#	INLET A	OUTLET B	NOTES
800332	1/2" PT	3/8" PT	Frame or Bracket Mount
800333	1/2" PT	1/2" PT	Direct Mount

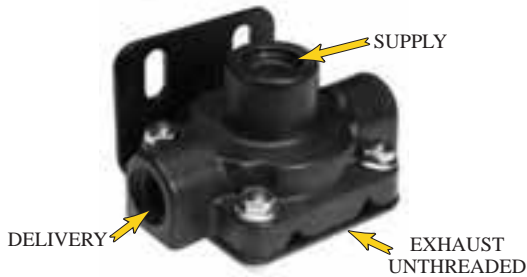

• QRN Quick Release valve.

SERVICE#	SUPPLY	DELIVERY	EXHAUST	CRACK PRESSURE	NOTES
065066	3/8" PT	2-3/8" PT	Unthreaded	0 PSI	
065067	1/2" PT	2-3/8" PT	Unthreaded	0 PSI	
065213	3/8" PT	2-3/8" PT	Unthreaded	4.5-7.5 PSI	
065214	3/8" PT	2-3/8" PT	Unthreaded	2-4.5 PSI	
065311	1/2" PT	2-3/8" PT	Unthreaded	4.5-7.5 PSI	
065347	1/2" PT	2-3/8" PT	Unthreaded	2-4.5 PSI	
800439	1/2" PT	2-3/8" PT	Unthreaded	2-4.5 PSI	
802741	3/8" PT	2-3/8" PT	Unthreaded	5-8 PSI	
802742	1/2" PT	2-3/8" PT	Unthreaded	5-8 PSI	
802743	3/8" PT	2-3/8" PT	Unthreaded	1 PSI MAX	
802744	3/8" PT	2-3/8" PT	Unthreaded	1 PSI MAX	
802745	1/2" PT	2-3/8" PT	Unthreaded	1 PSI MAX	



• QRN-2 Quick Release Valve.
• Non metallic Quick Release Valve.

SERVICE#	SUPPLY	DELIVERY	EXHAUST	CRACK PRESSURE	NOTES
800063	1/2" PT	2-3/8" NPT	-	0 PSI	
800064	3/8" PT	2-3/8" NPT	-	0 PSI	
800219	1/2" PT	2-1/2" NPT	-	0 PSI	

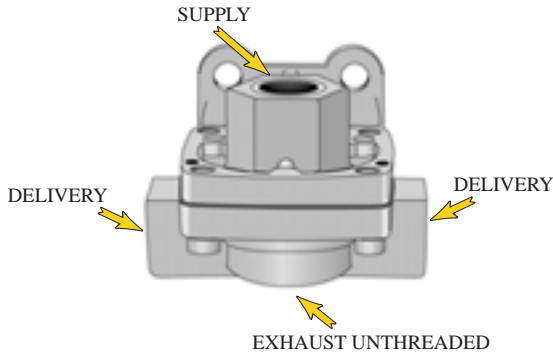

- **QR-1 Quick Release Valve.**
- Decreases the release time on a brake application.
- Exhausts air through itself rather than through the controlling valve.
- Weight .11 lbs.

SERVICE#	SUPPLY	DELIVERY	EXHAUST	CRACK PRESSURE	NOTES
102344	3/8" PT	2-3/8" PT	-	10-16 PSI	-
229813	3/8" PT	2-1/4" PT	-	0 PSI	-
229844	1/2" PT	2-1/4" PT	-	0 PSI	-
229859	3/8" PT	2-3/8" PT	-	0 PSI	-
229860	1/2" PT	2-3/8" PT	-	0 PSI	-
278483	1/2" PT	2-3/8" PT	-	5-8 PSI	-
281024	1/4" PT	2-1/4" PT	-	0 PSI	-
288251	3/8" PT	2-3/8" PT	3/8" PT	0 PSI	-
289042	3/8" PT	2-1/4" PT	-	1 PSI	W / INSERT
289525	3/8" PT	2-3/8" PT	-	1 PSI	W / INSERT

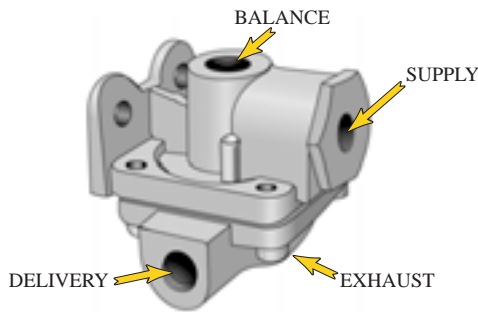

- **QR-1C Quick Release Valve and Double Check Valve.**
- Functions as a Quick Release Valve for the emergency side of the spring brakes.
- Double Check Valve prevents simultaneous application of the emergency side of the spring brakes (Anti-Compounding).
- Unless noted otherwise crack pressure is 0 PSI.
- Weight .14 lbs.

SERVICE#	SUPPLY	DELIVERY	BALANCE	EXHAUST	NOTES
107881	1/4" PT	2-3/8" PT	1/4" PT	1/2" W/Silencer	
289182	1/4" PT	2-1/4" PT	1/4" PT	-	
289714	1/4" PT	2-3/8" PT	1/4" PT	-	
800539	1/4" PT	2-3/8" PT	1/4" PT	-	1 PSI max differential

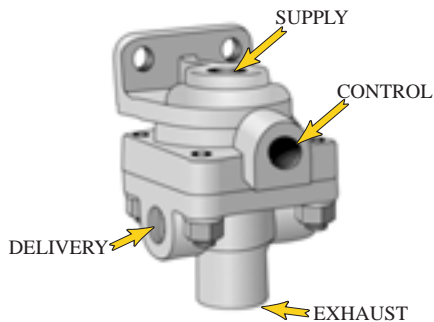

- **LQ-2 Limiting and Quick Release Valve.**
- Mounted on front axle.
- Limits front axle brake application by 50% on slippery roads, full application pressure on dry roads.
- Serves as a Quick Release Valve for the front axle.
- Weight 1.13 lbs.

SERVICE#	SUPPLY	DELIVERY	CONTROL	EXHAUST	NOTES
229505	3/8" PT	2-3/8" PT	1/4" PT	-	-
229507	1/2" PT	2-1/4" PT	1/4" PT	-	-
229509	3/8" PT	2-1/4" PT	1/4" PT	-	-
288417	3/8" PT	2-3/8" PT	1/4" PT	3/8" PT	-

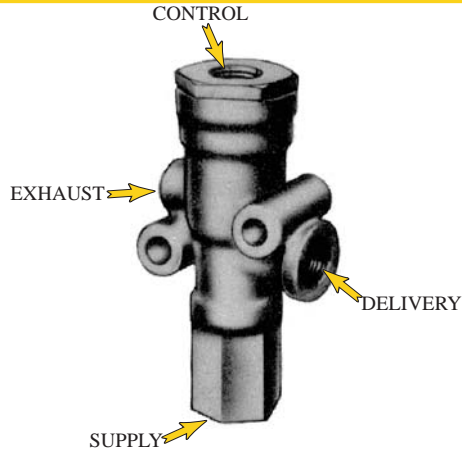

- **SV-3 Trailer Release Valve.**
- The trailer release valve is a pilot operated, non-graduating, pneumatic control valve. These valves are used to control air from a remote supply which is different than control air supply. They have definite opening and closing pressures and can be used to delay or sequence the action of other pneumatic devices.
- Weight 7 lbs.

SERVICE#	SUPPLY	DELIVERY	CONTROL	INLET OPENS AT	EXHAUST OPENS AT	NOTES
279824	1/4" PT	1/4" PT	1/4" PT	75 PSI	31 PSI	

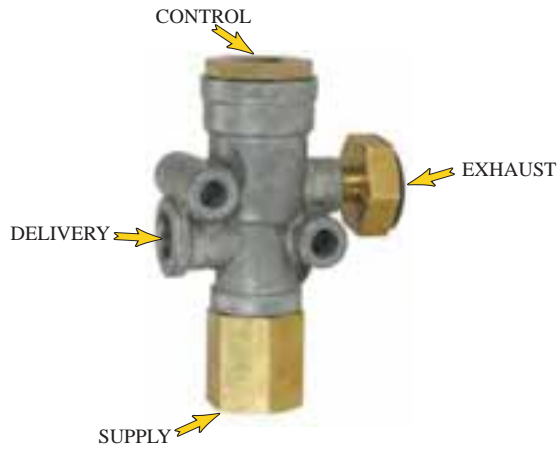

- **SV-4 Trailer Release Valve**

SERVICE#	SUPPLY	DELIVERY	CONTROL	BREATHER VALVE SIZE / SHAPE	NOTES
108769	1/4" PT	1/4" PT	1/4" PT	1" HEXAG	
109149	1/4" PT	1/4" PT	1/4" PT	9/16" 12 POINT	



- SC-3 Single Check Valve.
- SC-3 Valve replace the SC-1 and SC-2 valves.



SERVICE#	FIG.	INLET	OUTLET	NOTES
800369	1	3/4" PT	3/4" PT	Female inlet - Female outlet
800370	1	1/2" PT	1/2" PT	Female inlet - Female outlet
800372	2	1/2" PT	1/2" PT	Female inlet - Male outlet
800373	2	3/8" PT	3/8" PT	Female inlet - Male outlet
800374	2	1/4" PT	1/8" PT	Female inlet - Male outlet
800375	2	1/4" PT	1/4" PT	Female inlet - Male outlet
800376	3	1/2" PT	1/2" PT	Female inlet - Male outlet, 90°
801144	1	1/4" PT	1/4" PT	Female inlet - Female outlet

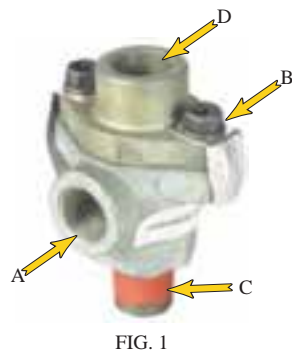

DC-4 Double Check Valve.

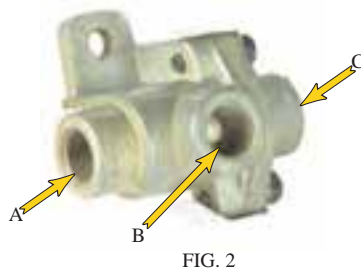

SERVICE#	FIG.	A	B	C	D	NOTES
278595N	1	1/4" PT	1/4" PT	1/2" PT	1/4" PT	
278596N	1	3/8" PT	3/8" PT	1/2" PT	1/4" PT	
278597N	1	1/4" PT	1/4" PT	3/8" PT	1/4" PT	
278598N	1	3/8" PT	3/8" PT	3/8" PT	1/4" PT	
278614N	2	3/8" PT	3/8" PT	3/8" PT	-	
278615N	2	1/4" PT	1/4" PT	1/4" PT	-	
280809N	1	3/8" PT	3/8" PT	3/8" PT	3/8" PT	



- **ST-1 Safety Valve.**
- Safety valves protect the air brake system against excessive pressure and should be installed in the first or supply reservoir. Should reservoir pressure exceed the pressure setting, the safety valve opens, allowing excess pressure to exhaust to atmosphere. The safety valve will automatically close when pressure is reduced. The ST-1 safety valve is adjustable.
- Weight 0.3 lbs.

SERVICE#	PRESS. SETTING	INLET	NOTES
205105	150 PSI	1/4" PT	
215057	200 PSI	1/4" PT	
217593	85-90 PSI	1/4" PT	
221154	175 PSI	1/4" PT	
223444	150 PSI	3/8" PT	
225674	45-48 PSI	1/4" PT	
275846	135 PSI	1/4" PT	
283745	150 PSI	3/8" PT	
283926	145 PSI	1/4" PT	
285528	150 PSI	3/8" PT	
286247	20 PSI	3/8" PT	



- **ST-3 Safety Valve.**
- The ST-3 Safety Valve is not adjustable

SERVICE#	INLET	PRESSURE SETTING	NOTES
11033	1/4" PT	150 PSI	
284142	1/4" PT	150 PSI	
284143	3/8" PT	150 PSI	
285835	1/4" PT	150 PSI	
285849	1/4" PT	175 PSI	
285850	1/4" PT	75 PSI	
288051	1/4" PT	150 PSI	
289487	3/8" PT	150 PSI	



• ST-4 Safety Valve.

SERVICE#	USED IN CONJUNCTION WITH	PRESSURE SETTING	THREAD	NO. OF HOLES	NOTES
131081		250 PSI	1/2" - 14 NPT	2	
800019		150 PSI	1/2" - 14 NPT	2	
800154		250 PSI	1/2" - 14 NPT	2	
800155		200 PSI	1/4" - 18 NPT	1	
800350	Dryer Reservoir Module	150 PSI	1/4" - 18 NPT	1	
800533		250 PSI	3/4" - 16 UNF-2A	2	
800534		250 PSI	M16 X 1.5-6 H	2	
801116		250 PSI	7/8" - 14 UNF-2A	2	

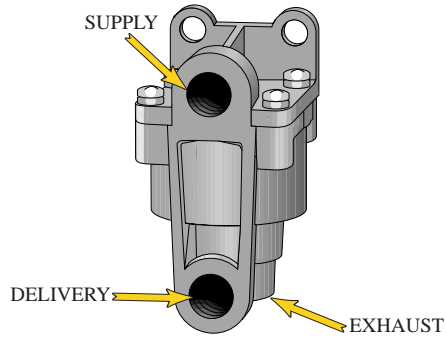

- **LQ-4 Ratio Valve.**
- Automatically reduces application pressure to the front service brakes.
- Preset “Hold-Off” pressure prevents the front brakes from operating until the “Hold Off” pressure is reached.
- Weight .8 lbs.

SERVICE#	SUPPLY	DELIVERY	EXHAUST	NOMINAL HOLD-OFF PRESSURE	NOMINAL EQUALIZING PRESSURE	NOTES
101311	3/8" PT	3/8" PT	-	20 PSI	70 PSI	
289144	3/8" PT	3/8" PT	-	4 PSI	60 PSI	
289148	3/8" PT	3/8" PT	-	10 PSI	65 PSI	

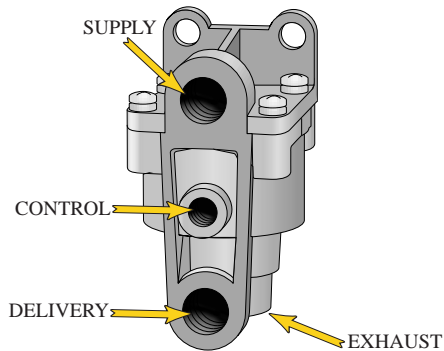

- **LQ-5 Bobtail Ratio Valve.**
- Used on the front (steering) axle of tractor air brake systems.
- Reduces brake application pressure during normal tractor/trailer operation.
- Delivers full brake pressure to the steering axle during bobtail mode.
- For tractor systems only.
- Weight .9 lbs.

SERVICE#	SUPPLY	DELIVERY	CONTROL	NOMINAL HOLD-OFF PRESSURE	NOMINAL EQUALIZING PRESSURE	NOTES
065154	3/8" PT	3/8" PT	1/8" PT	-	-	

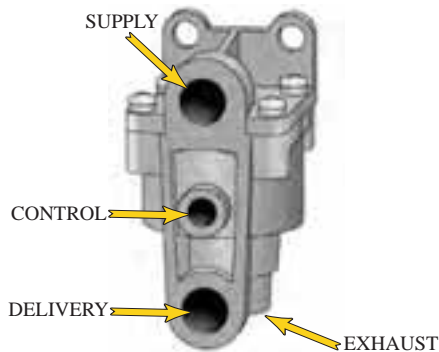

- **BP-1 Rear Air Brake Proportioning Relay Valve.**
- Part 104598 reduce the braking effort on the front axle.
- Part 106284 reduce the braking effort on the rear axle.
- The front and rear axle applications on the BP-1 not interchangeable.
- Weight 1 lb.

SERVICE#	SUPPLY	DELIVERY	CONTROL	NOMINAL INSHOT PSI	NOTES
104598	3/8" PT	3/8" PT	1/8" PT	4 PSI	Nominal Equalizing 50 PSI
106284	3/8" PT	3/8" PT	1/8" PT	8 PSI	Nominal Equalizing PSI 105

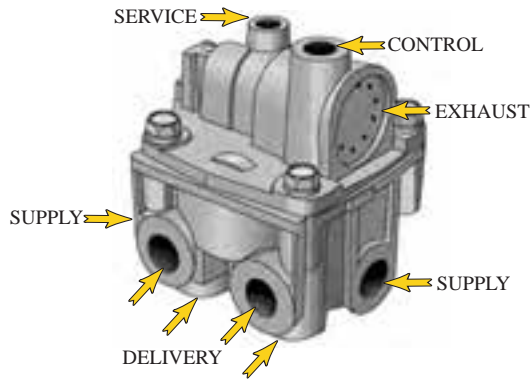

- **BP-R1 Bobtail Brake Proportioning Relay Valve.**
- Designed for use on tractor only.
- Functions as a standard relay valve and a proportioning valve.
- Weight 2.6 lbs.

SERVICE#	SUPPLY	DELIVERY	CONTROL	SERVICE	CRACK PRESSURE	NOTES
065145	2-1/2" PT	4-3/8" PT	1/8" PT	1/4" PT	4.0 PSI	
065146	2-1/2" PT	4-3/8" PT	1/8" PT	1/4" PT	5.5 PSI	

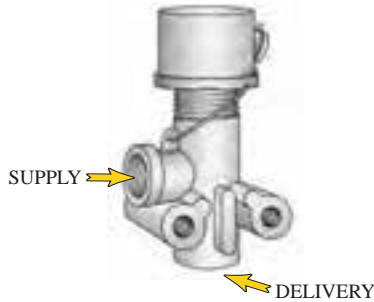

- **PR-2 Pressure Protection Valve.**
- Protects the brake system from accessory failure.
- Pressure setting is adjustable.
- Weight .4 lbs.

SERVICE#	SUPPLY	DELIVERY	NOMINAL CLOSING PRESSURE	NOTES
277147	1/4" PT	1/4" PT	65 PSI	
277148	1/4" PT	1/4" PT	85 PSI	
277222	1/4" PT	1/4" PT	95 PSI	
277226	1/4" PT	1/4" PT	60 PSI	
277227	1/4" PT	1/4" PT	75 PSI	
279505	1/4" PT	1/4" PT	65 PSI	W / Lockwire
281467	1/4" PT	1/4" PT	50 PSI	W / Lockwire
282517	1/4" PT	1/4" PT	60 PSI	W / Lockwire



- **PR-3 Pressure Protection Valve.**
- Pressure Protection.
- This valve is used with 101112 and 101622.

SERVICE#	RESERVOIR	NOMINAL CLOSING PRESSURE	NOTES
286460	1/4" PT	60 PSI	

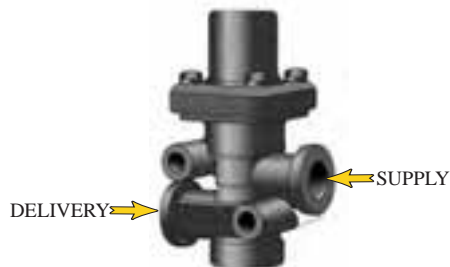

- **PR-4 Pressure Protection Valve.**
- Protects the brake system from accessory failure.
- Pressure setting is not adjustable.
- For use in aftercooler or air dryer installation where the compressor inlet is turbocharged.
- Weight .6 lbs.

SERVICE#	SUPPLY	DELIVERY	NOTES
286500	1/4" PT	1/4" PT	Nominal Closing Pressure - 85 PSI
103976	1/2" PT	1/2" PT	Nominal Closing Pressure - 45 PSI
288323	1/4" PT	1/4" PT	Nominal Closing Pressure - 70 PSI

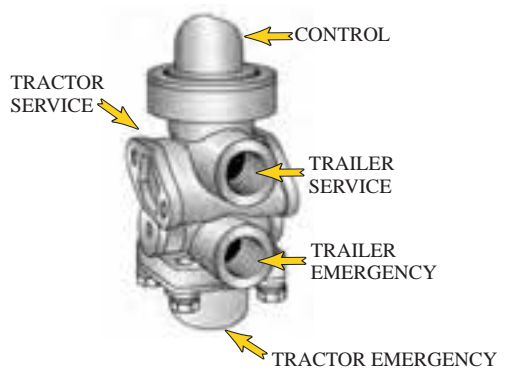

- **TP-2 Tractor Protection Valve.**
- Dual mounting.
- 3-line automatic style.
- Used in conjunction with dash mounted control valves.
- Weight .8 lbs.

SERVICE#	PORT LOCATIONS					
	TRACTOR CONTROL	TRACTOR SERVICE	TRACTOR EMERGENCY	TRAILER SERVICE	TRAILER EMERGENCY	STOPLIGHT SWITCH
227661	1/4" PT	3/8" PT	3/8" PT	3/8" PT	3/8" PT	-
227672	1/4" PT	3/8" PT	3/8" PT	1/2" PT	1/2" PT	-
283090	1/4" PT	3/8" PT	3/8" PT	1/2" PT	1/2" PT	1/8" PT

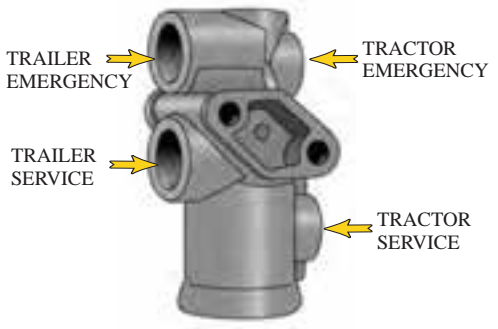

- **TP-3 Tractor Protection Valve.**
- TP-3 is used with PP-3 or PP-7 valve.
- Generally mounted on the rear of the tractor cab.
- 2-line nonautomatic style.
- Used in conjunction with dash mounted control valves.
- Weight .8 lbs.

SERVICE#	PORT LOCATIONS				NOTES
	TRACTOR SERVICE	TRACTOR EMERGENCY	TRAILER SERVICE	TRAILER EMERGENCY	
279000	3/8" PT	1/4" PT	1/2" PT	1/2" PT	Functions between 20-45 PSI
279692	3/8" PT	1/4" PT	3/8" PT	3/8" PT	Functions between 20-45 PSI
280830	3/8" PT	1/4" PT	1/2" PT	1/2" PT	

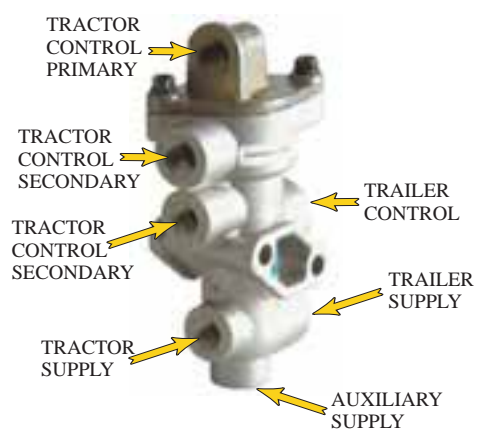

- **TP-3DC Tractor Protection Valve.**

SERVICE#	TRAILER CONTROL	TRAILER SUPPLY	TRACTOR CONTROL	TRACTOR SUPPLY	AUXILIARY SUPPLY	STOPLIGHT SWITCH
065706	1/2" PT	1/2" PT	2-3/8" PT	1/4" PT	1/4" PT	1/4" PT

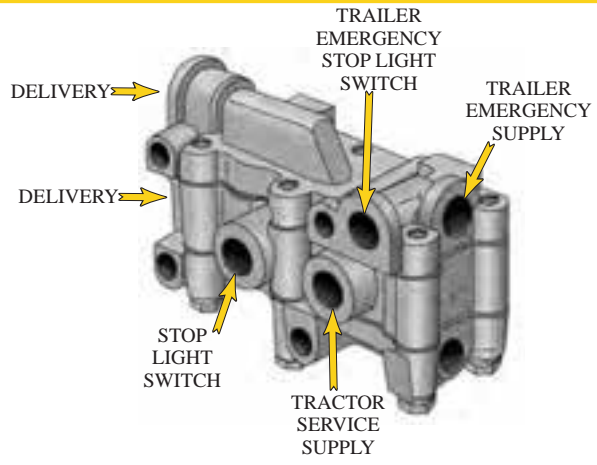

- **TP-4 Tractor Protection Valve.**
- Formerly VM-1 Control Valve Manifold.
- Combination of a tractor protection valve and two double check valves.
- Used in conjunction with a PP-3 or PP-7 to perform normal functions of a tractor protection valve.
- Weight 1.9 lbs.

SERVICE#	PORT LOCATIONS					NOTES
	DELIVERY	TRAILER EMERGENCY SUPPLY	TRAILER EMERGENCY STOP LIGHT SWITCH	STOPLIGHT SWITCH	TRACTOR SERVICE SUPPLY	
288301	2-3/8" PT	1/4" PT	1/4" PT	1/4" PT	1/4" PT	Ford "L" Model tractors only

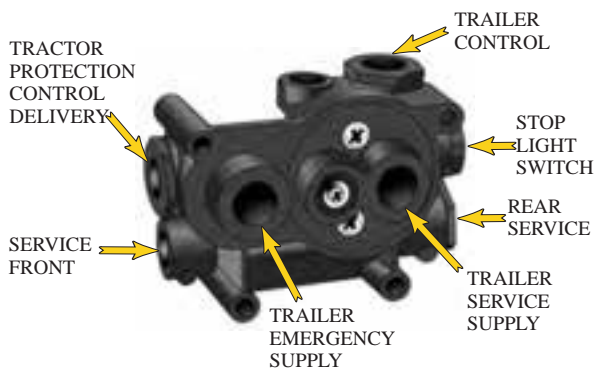

- **TP-5 Tractor Protection Valve.**
- Formerly VM-2 Control Valve Manifold.
- Performs same functions as the TP-4.
- Includes a quick release feature.
- *Mounting holes not threaded.
- **Use when TC-2 is not connected to the trailer control port of the TP-5 tractor protection valve.
- Weight 2.4 lbs.

SERVICE#	PORT LOCATIONS					
	REAR SERVICE	REAR TRLR. SERV. & EMER.	TRAILER SERVICE SUPPLY	TRAILER EMERGENCY SUPPLY	TRLR. CONTROL	STOPLIGHT SWITCH
106941*	3/8" PT	2-3/8" PT	1/2" PT	1/2" PT	3/8" PT	1/4" PT
288605	3/8" PT	2-3/8" PT	1/2" PT	1/2" PT	3/8" PT	1/4" PT
289253**	3/8" PT	2-3/8" PT	1/2" PT	1/2" PT	3/8" PT	1/4" PT



- **RV-1.**
- Pressure setting is adjustable.

SERVICE#	SUPPLY	DELIVERY
277144	1/4" PT	1/4" PT

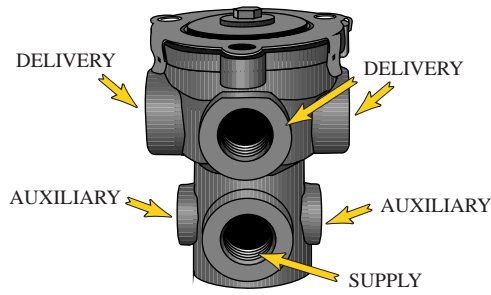

- E-2 & E-3 Foot Valve.
- Floor mounted.
- Treadle or Lever actuated.
- Used in single circuit systems.
- Weight 1.5 lbs.

SERVICE#	SUPPLY	DELIVERY	AUXILIARY	NOTES
229500	2-1/2" PT	4-3/8" PT	2-1/4" PT	E-2 Foot Valve
229501	2-1/2" PT	4-1/2" PT	2-1/4" PT	E-2 Foot Valve
277863	2-1/2" PT	4-1/2" PT	2-1/4" PT	E-3 Ft. Vlv., Slightly Longer Plunger Than E-2
278998	2-1/2" PT	4-1/2" PT	3-1/4" PT	E-3 Ft. Vlv., Slightly Longer Plunger Than E-2

• E-4 Dual Circuit Foot Valve.

SERVICE#	SUPPLY 1	SUPPLY 2	DEL. #1	DEL. #2	NOTES
279750	1/2" PT	1/2" PT	1/2" PT	1/2" PT	

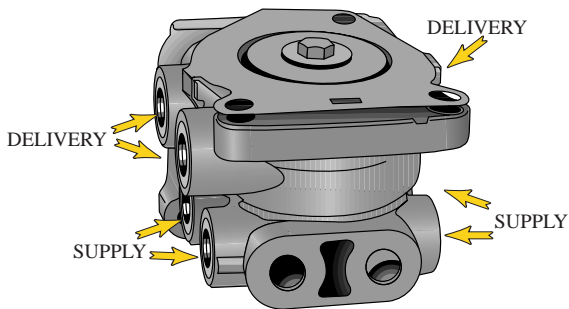

- E-5 Foot Valve.
- Firewall mounted.
- Mounted in cab of truck.
- Suspended pedal.
- Used in single circuit systems.
- Weight 2.1 lbs.

SERVICE#	SUPPLY	DELIVERY	EXHAUST	NOTES
279950	5-1/4" PT 1-1/2" PT	1-1/2" PT 2-1/4" PT 1-3/8" PT	-	-

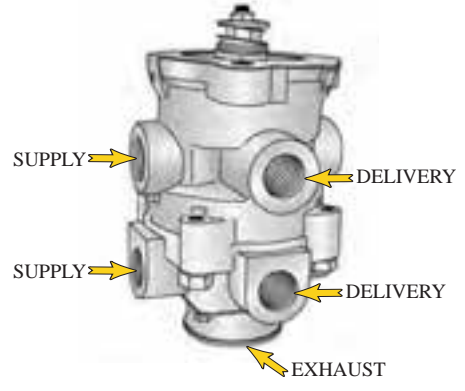

- E-6 Dual Circuit Foot Valve.
- Floor mounted, treadle or lever operated.
- Two separate supply and delivery circuits for service and secondary braking.
- Weight 4.8 lbs.

SERVICE#	SUPPLY	DELIVERY	AUXILIARY	NOTES
286171	4-3/8" PT	4-3/8" PT	-	-



- E-6 Dual Circuit Foot Valve.
- Ford flange mount.

SERVICE#	SUPPLY	DELIVERY	NOTES
104308	4-3/8" PT	4-3/8" PT	

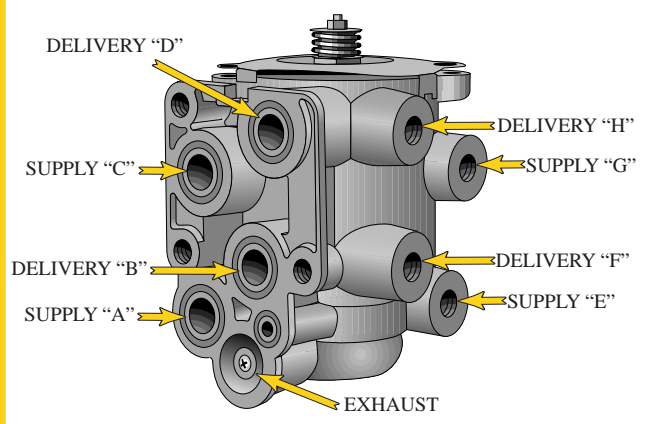

- E-7 Foot Valve.
- Firewall mounted.
- Suspended pedal.
- Dual circuit valve with two separate supply and delivery circuits.
- Weight 3.3 lbs.

SERVICE#	Port Thread Sizes & Locations												EXHAUST	NOTES
	A	B	C	D	E	F	G	H	J	K	L	M		
101818	1/2"	1/2"	1/2"	1/2"	1/4"	3/8"	1/4"	3/8"	1/4"	3/8"	1/4"	3/8"	-	Exhaust port contains diaphragm
284760	No Thd	No Thd	No Thd	No Thd	Sup 1/4"	Del -	Sup 1/4"	Del -	Sup -	Del -	Sup -	Del -		Exhaust port contains diaphragm
286773	1/2"	1/2"	1/2"	1/2"	1/4"	1/4"	1/4"	1/4"	1/4"	1/4"	1/4"	1/4"	1/2"	-
286774	1/2"	1/2"	1/2"	1/2"	1/4"	1/4"	1/4"	1/4"	1/4"	1/4"	1/4"	1/4"	1/2"	-
286775	1/2"	1/2"	1/2"	1/2"	1/4"	1/4"	1/4"	1/4"	1/4"	1/4"	1/4"	1/4"	1/2"	-
287411	1/2"	1/2"	1/2"	1/2"	1/4"	1/4"	1/4"	1/4"	3/8"	3/8"	3/8"	3/8"	1/2"	-
287564	1/2"	1/2"	1/2"	1/2"	1/4"	3/8"	1/4"	3/8"	1/4"	1/4"	1/4"	1/4"	1/2"	Exhaust port contains diaphragm
288383	1/2"	1/2"	1/2"	1/2"	1/4"	1/4"	1/4"	1/4"	1/4"	1/4"	1/4"	1/4"	1/2"	Exhaust port contains diaphragm

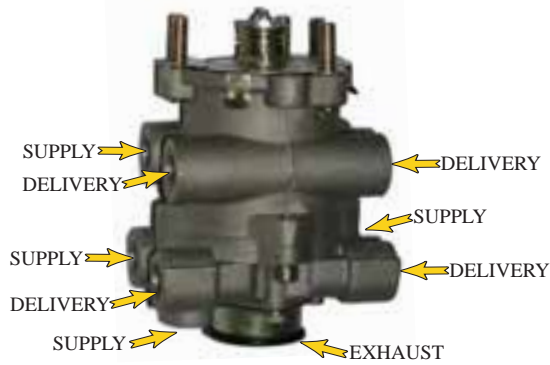

• E-8P Dual Brake Valve.

SERVICE#	REPLACE E-12	SUPPLY	DELIVERY	EXHAUST	NOTES
800629	065313, 800583	5-3/8" PT	4-3/8" PT		Lower Body Rotated 90°
800630	065458	5-3/8" PT	4-3/8" PT		Lower Body Rotated 90°
800631	065460, 800407	5-3/8" PT	4-3/8" PT	1/2" NPT	1/2 NPT Exhaust

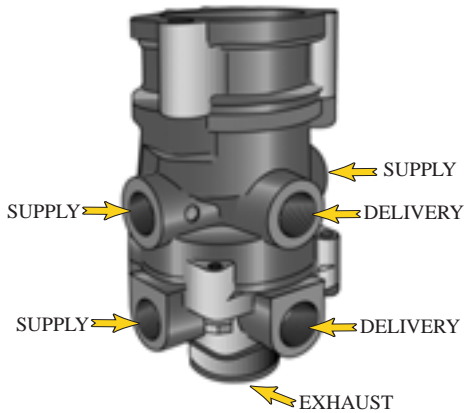

- E-10 Dual Circuit Foot Valve.
- Floor mounted, treadle operated.
- Two separate supply and delivery circuits for service and secondary braking.
- Used in dual or split air brake systems.
- Weight 4.8 lbs.

SERVICE#	SUPPLY	DELIVERY	EXHAUST	NOTES
101100	4-3/8" PT	4-3/8" PT	-	-



• E-10P Dual Brake Valve.

SERVICE#	REPLACE E-15	SUPPLY	DELIVERY	NOTES
800632	065315	4-3/8" PT	4-3/8" PT	-
	800318	4-3/8" PT	4-3/8" PT	

SERVICE#	REPLACE E-15R	SUPPLY	DELIVERY	NOTES
800632	800319	4-3/8" PT	4-3/8" PT	-

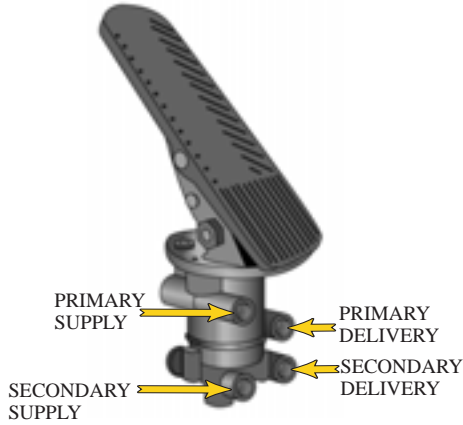

- **E-12 & E-15 Foot Valve.**
- Firewall mounted.
- Mounted in cab of truck.
- Treadle and mounting plate not furnished.
- Dual circuit valve with two separate supply and delivery circuits.
- **Pedal not included.**
- Weight 2.8 lbs.

SERVICE#	SUPPLY PRIMARY	SUPPLY SECONDARY	DELIVERY PRIMARY	DELIVERY SECONDARY	NOTES
065313	2-3/8" PT	2-3/8" PT	2-3/8" PT	2-3/8" PT	
800318	2-3/8" PT	2-3/8" PT	2-3/8" PT	2-3/8" PT	

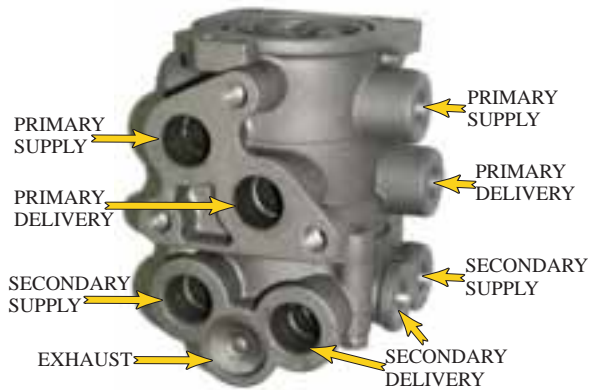

- **E-14 Foot Valve.**
- Firewall mounted.
- Pedal and mounting plate not furnished.
- Dual circuit valve with two separate supply and delivery circuits.
- Pedal not included.
- Weight 8.0 lbs.

SERVICE#	SUPPLY	DELIVERY	EXHAUST	NOTES
065314	4-3/8" PT	4-3/8" PT	-	Exhaust port not threaded
065317	4-3/8" PT	4-3/8" PT	-	Exhaust port threaded 1/2" PT
065395	3/8-18	3/8-18	-	Used With Manifold

STYLE "A"
(New Style)

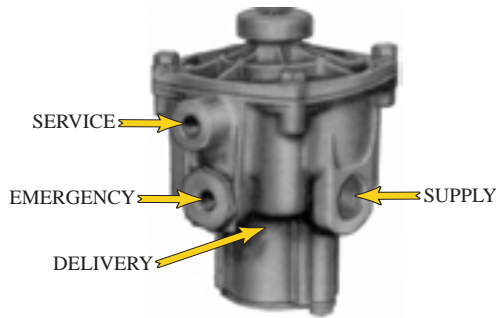

- **RE-4 Relay Emergency Valve.**
- A dual function valve used on trailers.
- A relay valve that applies and releases the service brakes.
- An emergency feature that automatically applies the service brakes in the event that supply air is lost.
- Normally used on pre FMSS-121 vehicles and off road application.
- Weight 4.7 lbs.

SERVICE#	SUPPLY	DELIVERY	EMERGENCY	SERVICE	NOTES
277446	2-3/4" PT	4-1/4" PT	1-1/4" PT	1/4" PT	-

STYLE "B"
(Old Style)

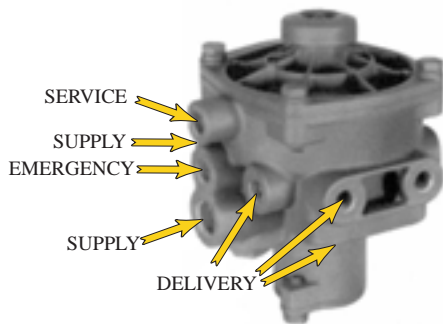

- **RE-4 Relay Emergency Valve.**
- A dual function valve used on trailers.
- A relay valve that applies and releases the service brakes.
- An emergency feature that automatically applies the service brakes in the event that supply air is lost.
- Normally used on pre FMSS-121 vehicles and off road application.
- Weight 4.7 lbs.

SERVICE#	SUPPLY	RESERVOIR	DELIVERY	CONTROL	EMERGENCY	NOTES
229434	1-3/4" PT 2-1/2" PT	2-1/2" PT 1-3/4" PT	6-1/4" PT	2-1/4" PT	2-1/4" PT	-

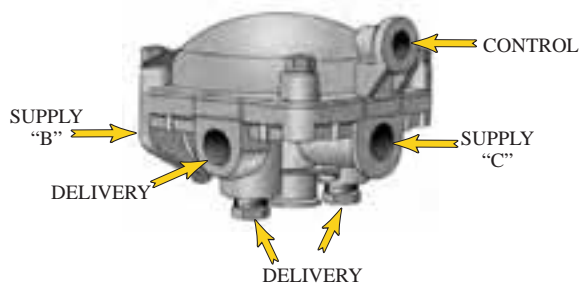

- **R-6 Relay Valve.**
- 4 port delivery.
- Weight 2.3 lbs.

SERVICE#	SUPPLY		DELIVERY	CONTROL	CRACK PRESSURE	NOTES
	B	C				
279180		3/8" PT	4-3/8" PT	1/4" PT	2 PSI	180° Service Port Angle
279952	3/4" PT	3/8" PT	4-3/8" PT	1/4" PT	2 PSI	180° Service Port Angle
280375		1/2" PT	4-3/8" PT	1/4" PT	2 PSI	90° Service Port Angle
283940		3/8" PT	4-3/8" PT	1/4" PT	2 PSI	Ford application, 270° Service Port Angle
279952 - 280651	3/4" PT	3/8" PT	4-3/8" PT	1/4" PT	2 PSI	180° Service Port Angle

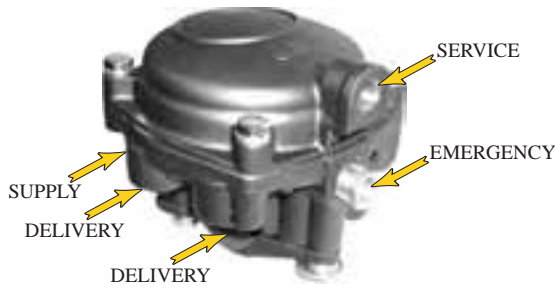

- RE-6 and RE-6NC Relay Emergency Valve.
- Dual function valve used on trailers.
- Used on pre-FMVSS-121 vehicles and off road applications.
- 4 port delivery.
- 284280X - Initial Emergency High Pressure Application
- 065451 (RE-6NC) must be used in conjunction with a PR-3 reservoir control valve.
- Weight 3.1 lbs.

SERVICE#	SUPPLY	DELIVERY	SERVICE	EMERGENCY	INTL. EMER. APPL. PRES.	MAX. EMER. REL. PRES.
065451 (RE-6NC)	1-3/8" PT / 1-3/4" PT	4-1/4" PT	1/4" PT	1/4" PT		
101197	1-3/8" PT / 1-3/4" PT	4-3/8" PT	1/4" PT	1/4" PT	65 ± 5 PSI	110 PSI
281860	1-3/8" PT / 1-3/4" PT	4-1/4" PT	1/4" PT	1/4" PT		
281865	1-3/8" PT / 1-3/4" PT	2-1/4" PT / 2-3/8" PT	1/4" PT	1/4" PT	50 ± 5 PSI	95 PSI
284280	1-3/8" PT / 1-3/4" PT	2-1/4" PT / 2-3/8" PT	1/4" PT	1/4" PT	65 ± 5 PSI	110 PSI

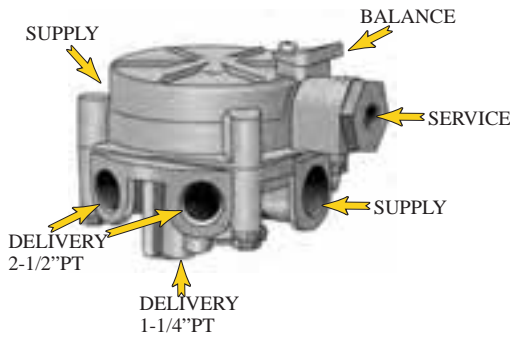

- R-8 Relay Valve.
- 1/8" balance valve port located under the exhaust cover.
- Controls spring brakes and service brakes.
- 3 port delivery.
- Weight 2.9 lbs.

SERVICE#	SUPPLY	DELIVERY	SERVICE	CRACK PRESSURE	PORT ROTATION	BALANCE	NOTES
286370	2-3/4" PT/1-1/4" PT	2-1/2" PT	1/4" PT	3 PSI	90°	1/8" PT	-
286371	2-3/4" PT	2-1/2" PT/1-1/4" PT	1/4" PT	3 PSI	90°	1/8" PT	No exhaust cover
287224	1-3/4" PT	2-1/2" PT/1-1/4" PT	1/4" PT	3 PSI	270°	1/8" PT	-
287260	2-3/4" PT/1-1/4" PT	2-1/2" PT	1/4" PT	3 PSI	180°	1/8" PT	No exhaust cover
288369	2-3/4" PT	2-1/2" PT	1/4" PT	3 PSI	180°	1/8" PT	-
288781	2-3/4" PT	2-1/2" PT	1/4" PT	3 PSI	180°	1/8" PT	Waterproof

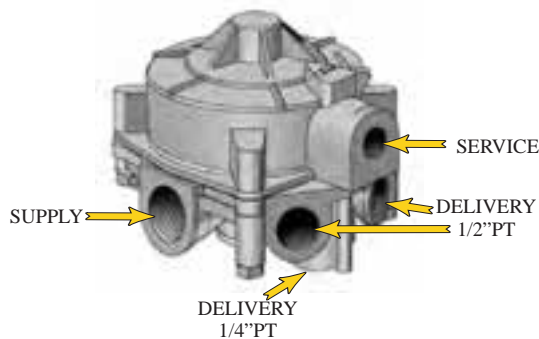

- R-8P Pressure Equalizing Relay Valve.
- Designed for use on semitrailer converter dollies.
- Weight 3 lbs.

SERVICE#	SUPPLY	DELIVERY	SERVICE	CRACK PRESSURE	NOTES
287114	2-3/4" PT	2-1/2" PT 1-1/4" PT	3/8" PT	0 PSI	-

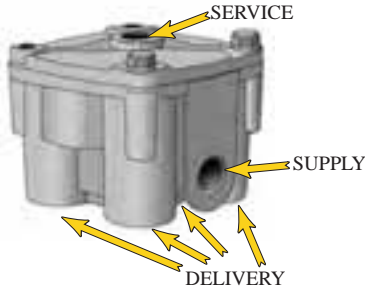

- **R-12 Relay Valve.**
- Four port delivery located on the bottom of the valve.
- Weight 2.3 lbs.

SERVICE#	SUPPLY	DELIVERY	SERVICE	CRACK PRESSURE	NOTES
065104	1/2" PT	4-3/8" PT	1/4" PT	4.0 PSI	-
065181	1/2" PT	4-1/2" PT	1/4" PT	5.5 PSI	-
102165	1/2" PT	4-3/8" PT	1/4" PT	4.0 PSI	-
102626	1/2" PT	4-1/2" PT	1/4" PT	4.0 PSI	-
103912	1/2" PT	4-1/2" PT	1/4" PT	7.5 PSI	-
104561	1/2" PT	4-3/8" PT	1/4" PT	5.5 PSI	-
800365	1/2" PT	4-3/8" PT	1/4" PT	4.0 PSI	-

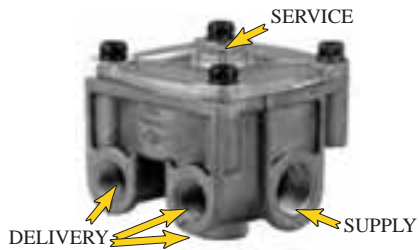

- **R-12 Relay Valve**
- Two port delivery located on the bottom of the valve (2x) and on the side (2x).

SERVICE#	SUPPLY	DELIVERY VERTICAL	DELIVERY HORIZONTAL	SERVICE	CRACK PRESSURE	NOTES
065206	2-1/2" PT	2-3/8" PT	2-3/8" PT	1/4" PT	5.5 PSI	
065303	2-1/2" PT	2-3/8" PT	2-3/8" PT	1/4" PT	4.0 PSI	
800095	2-1/2" PT	2-3/8" PT	2-3/8" PT	1/4" PT	4.0 PSI	
800441	2-1/2" PT	2-3/8" PT	2-3/8" PT	1/4" PT	5.5 PSI	
800483	2-1/2" PT	2-3/8" PT	2-3/8" PT	1/4" PT	5.5 PSI	
800484	2-1/2" PT	2-3/8" PT	2-1/2" PT	1/4" PT	5.5 PSI	
800485	2-1/2" PT	2-3/8" PT	2-1/2" PT	1/4" PT	4.0 PSI	
800486	2-1/2" PT	2-3/8" PT	2-1/2" PT	1/4" PT	4.0 PSI	
800508	2-1/2" PT	2-3/8" PT	2-1/2" PT	1/4" PT	5.5 PSI	

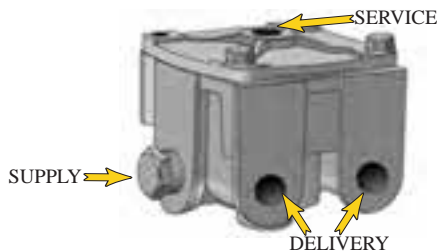

- **R-12H Relay Valve.**
- Horizontal mount.
- Two port delivery located on the side of valve.
- Weight 2.3 lbs.

SERVICE#	SUPPLY	DELIVERY	SERVICE	CRACK PRESSURE	NOTES
065125	2-1/2" PT	2-1/2" PT	1/4" PT	5.5 PSI	-
065309	2-1/2" PT	2-1/2" PT	1/4" PT	4.0 PSI	-
065546	2-1/2" PT	2-1/2" PT	1/4" PT	4.0 PSI	-
103009	2-3/4" PT	2-1/2" PT	1/4" PT	4.0 PSI	-
104165	2-3/4" PT	2-1/2" PT	1/4" PT	7.5 PSI	-
800238	2-3/4" PT	2-1/2" PT	1/4" PT	4.0 PSI	-
800305	2-1/2" PT	2-1/2" PT	1/4" PT	4.0 PSI	-
800365	2-1/2" PT	2-1/2" PT	1/4" PT	4.0 PSI	-
800366	2-1/2" PT	2-3/8" PT	1/4" PT	5.5 PSI	-

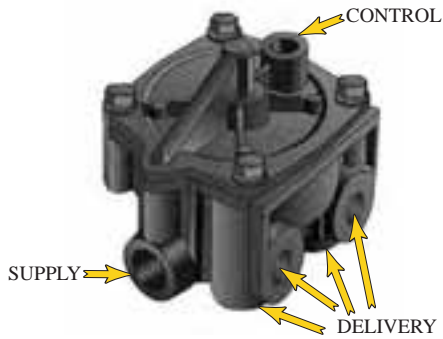

- **R-12P Pilot Relay Valve.**
- 4 port delivery located on the bottom of valve.
- 2 X and on the side 2 X.
- Weight 2.1 lbs.

SERVICE#	SUPPLY	DELIVERY	CONTROL	CRACK PRESSURE	NOTES
065476 / 109264	2-1/2" PT	4-3/8" PT	1/4" PT	-	-

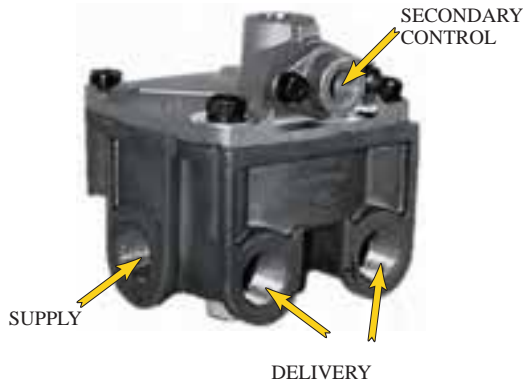

- **R-12DC Relay Valve with Biased Double Check.**
- 2 horizontal delivery ports.

SERVICE#	SUPPLY	DELIVERY	CRACK PRESSURE	NOTES
800470	2-1/2" NPT	2-1/2" NPT	4 PSI	
800471	2-1/2" NPT	2-1/2" NPT	5.5 PSI	
800627	2-1/2" NPT	2-1/2" NPT	4 PSI	

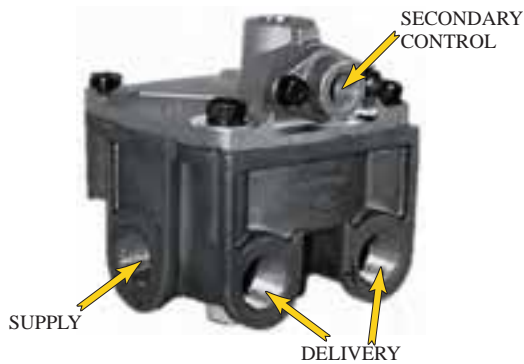

- **R-12DC Relay Valve with Biased Double Check.**
- 4 horizontal and 2 vertical delivery ports.

SERVICE#	SUPPLY	DELIVERY HORIZONTAL	DELIVERY VERTICAL	CRACK PRESSURE	NOTES
800481	2-1/2" NPT	2-1/2" NPT	2-3/8" NPT	4 PSI	
801305	2-1/2" NPT	2-1/2" NPT	2-3/8" NPT	4 PSI	
801381	2-1/2" NPT	2-1/2" NPT	2-3/8" NPT	5.5 PSI	

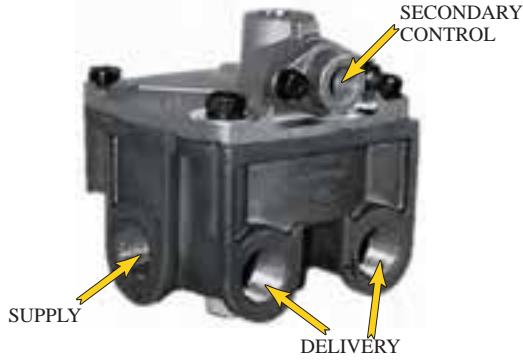

- R-12DC Relay Valve with Biased Double Check.
- 4 vertical delivery ports.

SERVICE#	SUPPLY	DELIVERY VERTICAL	CRACK PRESSURE	NOTES
800477	1/2" NPT	4-1/2" NPT	4 PSI	
800479	1/2" NPT	4-1/2" NPT	4 PSI	

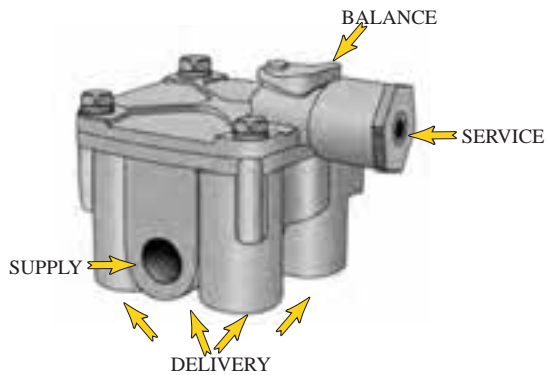

- R-14 Relay Valve.
- Vertical delivery ports.
- 1/8" balance port located under the exhaust cover.
- Controls spring brakes and service brakes.
- 4 port delivery.
- Weight 2.3 lbs.

SERVICE#	SUPPLY	DELIVERY	SERVICE	BALANCE	CRACK PRESSURE	NOTES
065430	1/2" PT	2-3/8" PT / 2-1/2" PT	1/4" PT	1/8" PT	4.0 PSI	Delivery: 2 X horizontaland / 2 X vertical
103028	1/2" PT	4-1/2" PT	1/4" PT	1/8" PT	4.0 PSI	-
103833	1/2" PT	4-1/2" PT	1/4" PT	1/8" PT	7.5 PSI	-
106313	1/2" PT	4-1/2" PT	1/4" PT	1/8" PT	5.5 PSI	-

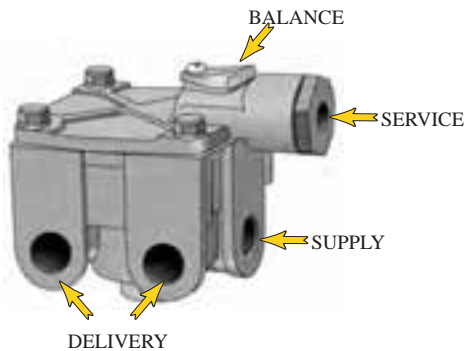

- R-14-H Relay Valve.
- Horizontal mount.
- 1/8" balance port located under the exhaust cover.
- Controls spring brakes and service brakes.
- 2 port delivery.
- Weight 2.3 lbs.

SERVICE#	SUPPLY	DELIVERY	SERVICE	BALANCE	CRACK PRESSURE	NOTES
103010	2-3/4" PT	2-1/2" PT	1/4" PT	1/8" PT	4.0 PSI	-
103294	2-3/4" PT	2-1/2" PT	1/4" PT	1/8" PT	5.5 PSI	-
103835	2-3/4" PT	2-1/2" PT	1/4" PT	1/8" PT	7.5 PSI	-
104345	2-3/4" PT	2-1/2" PT	1/4" PT	1/8" PT	5.0 PSI	-
104574	2-1/2" PT	2-1/2" PT	1/4" PT	1/8" PT	4.0 PSI	-

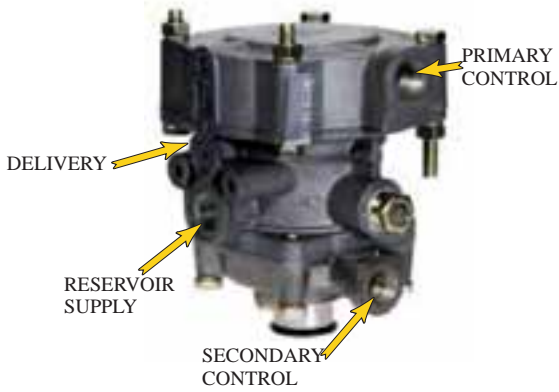

• Dual Relay Valve.

SERVICE#	SUPPLY RESERVOIR	DELIVERY	PRIMARY CONTROL	SECONDARY CONTROL	NOTES
KY1122/7		3/8" PT	3/8"PT	3/8"PT	

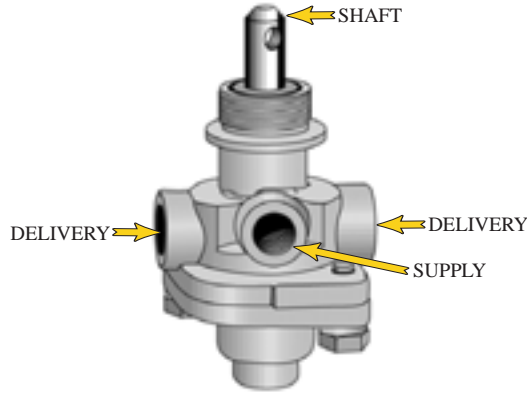

- **PP-1 Push-Pull Control Valve.**
- Commonly used to control parking and emergency brakes.
- Weight .6 lbs.

SERVICE#	SUPPLY	DELIVERY	SHAFT SIZE	NOTES
276566	1/8" PT	2-1/8" PT		Automatic Release Pressure - 20 PSI
276567	1/8" PT	2-1/8" PT		Automatic Release Pressure - 40 PSI
276569	1/8" PT	2-1/8" PT		Automatic Release Pressure - 30 PSI
278450	1/8" PT	2-1/8" PT		
281587	1/8" PT	2-1/8" PT		Auto Release Pressure - 40 PSI, Remote / Mount - 1/4" Female Thread In Shaft
282499	1/8" PT	2-1/4" PT		Automatic Release Pressure - 40 PSI
283828	1/8" PT	2-1/8" PT		Automatic Release Pressure - 60 PSI
287417	1/8" PT	2-1/4" PT		Automatic Release Pressure - 30 PSI
287600	1/8" PT	2-1/4" PT		Automatic Release Pressure - 40 PSI
287637	1/8" PT	2-1/8" PT		Non-Automatic Release Pressure

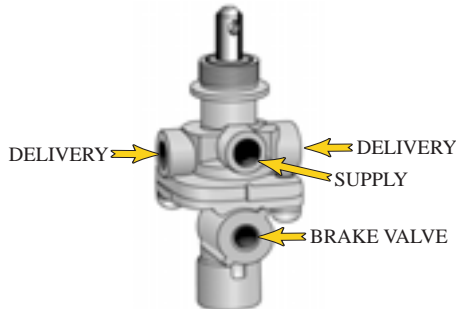

- **PP-2 Hand Control Valve, (Pressure Balanced).**
- Push-Pull Type Valve.
- Use with parking and emergency brakes.
- Anti-compounding port which prevents simultaneous application of both the service and parking brakes.
- Weight .8 lbs.

SERVICE#	SUPPLY	DELIVERY	BRAKE VALVE	SHAFT SIZE	NOTES
276462	1/8" PT	2-1/8" PT	1/8" PT		Automatic Release Pressure - 40 PSI
280454	1/8" PT	2-1/8" PT	1/8" PT		Auto Release Pressure - 40 PSI, Shaft 1/4"-20 THD

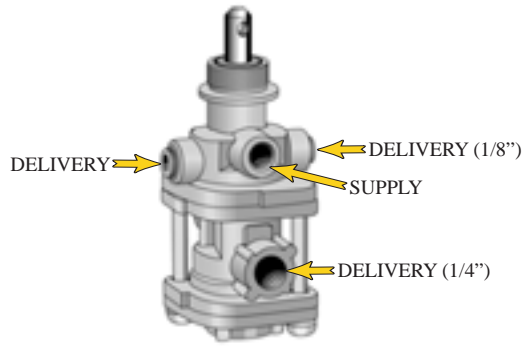

- **PP-3 Hand Control Valve, (Automatic Tripper).**
- Push-Pull Type Valve.
- Primarily used with a two-line tractor protection valve.
- Tripper Exhaust at 30 PSI and Charges above 50 PSI. Plunger Trips at 40 PSI and Charges Manually.

SERVICE#	SUPPLY	DELIVERY	NOTES
279787	1/8" PT	1/8" PT	Remote Mount - 1/4-20 Thread
		1/4" PT	
288746	1/8" PT	1/8" PT	-
		1/4" PT	
289477	1/8" PT	2-1/8" PT	-
		1/4" PT	
289512	1/8" PT	2-1/8" PT	Remote Mount - 1/4" Female Thread In Shaft
		1/4" PT	

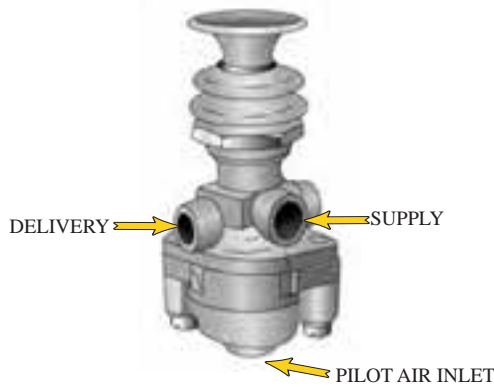

- **PP-5 Hand Control Valve.**
- Can automatically be moved to exhaust position by applying a low signal from another control valve to the PP-5 Pilot Port.
- Used in conjunction with vehicle torque converter systems, engine speed control systems and some parking brake systems.
- **KNOB NOT INCLUDED.**
- Weight 6 lbs.

SERVICE#	SUPPLY	DELIVERY	PILOT AIR INLET	AUTOMATIC RELEASE PRESSURE	PILOT PRESSURE	NOTES
281946N	1/8" PT	2-1/8" PT	1/8" PT	40 PSI	18 PSI	
284744N	1/8" PT	2-1/8" PT	1/8" PT	MANUAL	24 PSI	

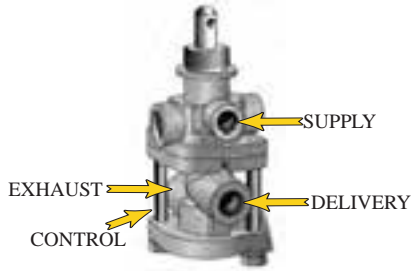

- **PP-7 Trailer Supply Hand Valve.**
- Steering column mount.
- Generally used on tractors and provides modulated control on trailer brakes only.
- Automatic, release pressure 40 PSI.
- Weight 1.1 lbs.

SERVICE#	SUPPLY	DELIVERY	CONTROL	THREADED EXHAUST PORT	NOTES
101479	1/8" PT	1/4" PT	1/8" PT		Stem Diameter 3/8"
288239N	1/8" PT	1/4" PT	1/8" PT	-	Stem Diameter 3/8"
288240	1/8" PT	1/4" PT	1/8" PT	-	Remote Mount - 1/4" Female Thread In Shaft, Stem Diameter 1/2"
288241X	1/8" PT	1/4" PT	1/8" PT	1/4" NPTF	Stem Diameter 5/16"
288242	1/8" PT	1/4" PT	1/8" PT	-	Remote Mount - 1/4" Female Thread In Shaft, Stem Diameter 1/2"
288721	1/8" PT	1/4" PT	1/8" PT	1/4-18 NPTF	Stem Diameter 3/8"

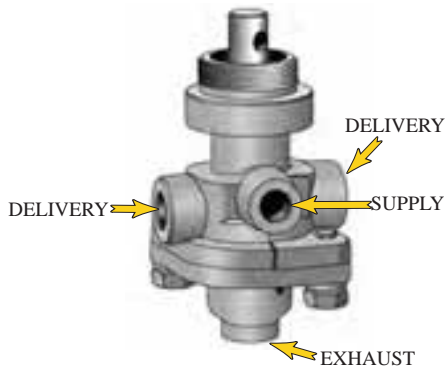

- **PP-8 Hand Control Valve.**
- Manually operated.
- Generally used on tractor parking brakes.
- Supplied without knob or mounting hardware.
- Weight .6 lbs.

SERVICE#	SUPPLY	DELIVERY	EXHAUST	NOTES
287238N	1/8" PT	2-1/8" PT	1/8" PT	Push-Pull Control Valve
287240	1/8" PT	2-1/8" PT	1/8" PT	Remote mount 1/4" female thread in shaft
287418N	1/8" PT	2-1/4" PT	1/8" PT	Push-Pull Control Valve
289259	1/8" PT	2-1/8" PT	1/8" PT	Remote mount 1/4" female thread in shaft

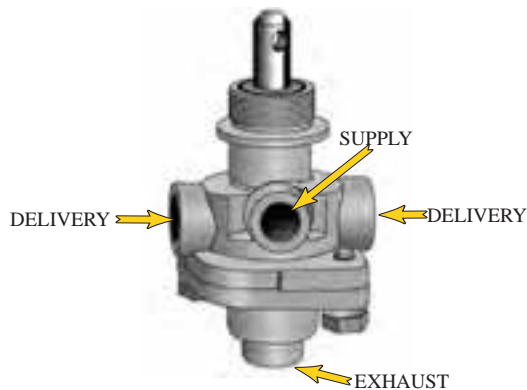

- **RD-3 Push Type Control Valve.**

SERVICE#	SUPPLY	DELIVERY	EXHAUST	NOTES
104644	1/8" PT	2-1/8" PT	-	Stem Threaded 1/4" - 28
286211N	1/8" PT	2-1/8" PT	-	



- PP-DC Control Valve
- Maintenance Kit 5006939



Fig. 1

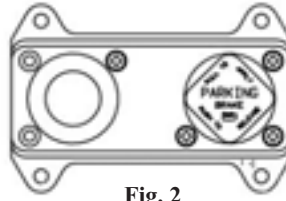

Fig. 2

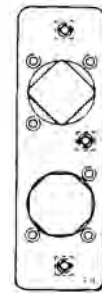
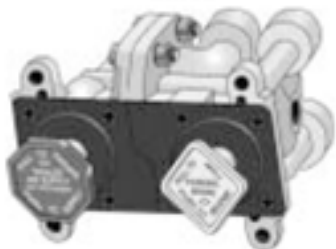

Fig. 3

SERVICE#	FIG.	MOUNTING HOLE	PORT TYPE	NOTES
065643	2	.27" DIA.	Push-to-connect (3/8" O.D. Tubing)	
065661	1	1/4 - 20 THD.	Push-to-connect (3/8" O.D. Tubing)	
065690	1	.27" DIA.	Push-to-connect (3/8" O.D. Tubing)	
800004	2	#10-24 THD	Push-to-connect	
800034	2	.27" DIA.	1/4" - 18 N.P.T.	
800142	1	1/4 - 20 THD.	1/4" - 18 N.P.T.	
800309	3	M - 6	Push-to-connect (3/8" O.D. Tubing)	
5000359	2	1/4 - 20 THD.	1/4" - 18 N.P.T.	

ORIGINAL PART#	REPLACED BY THIS PART #	ORIGINAL PART #	REPLACED BY THIS PART #	NOTES
109636	065643	109881	065690	
109795	065661	5000054	800004	
109880	065661	50000360	800034	



- MV-2 Valve (Manifold)
- Non-metallic assembly.
- Control Panel Mounting in truck or tractor.
- Two push-pull valves and a dual circuit supply valve.
- Knobs not included.

SERVICE#	RESERVOIR -1	RESERVOIR-2	DELIVERY TRACTOR	DELIVERY TRAILER	AUX. SUPPLY	EXHAUST	MOUNTING HOLE
101437	1/4" PT	1/4" PT	1/4"	1/4"	1/4"	1/4"	1/4" Unthreaded
101890	1/4" PT	1/4" PT	1/4" PT	1/4" PT	1/4" PT	1/4" PT	1/4" - 20 THD
102027	1/4" PT	1/4" PT	1/4" PT	1/4" PT	1/4" PT	1/4" PT	10 - 24 THD



MV-3 (MANIFOLD)

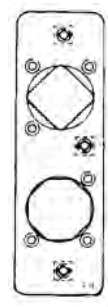
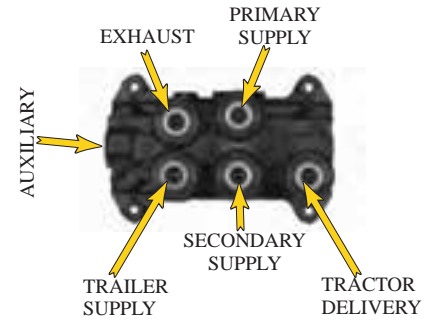

FIG. 3

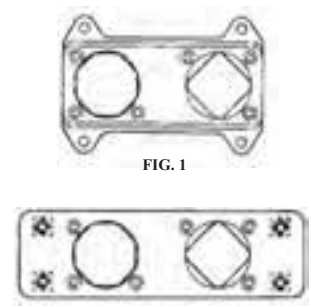

FIG. 1

FIG. 2

The **MV-3** (Manifold) Valve is integrated control assembly designed for control panel mounting in a truck-tractor. This non-metallic assembly consists of two push-pull valves and a dual circuit supply valve. It provides all the federal legal requirements for trailer air supply and parking brake control plus an additional feature permitting the tractor parking brakes to be applied while air is supplied to the trailer. The MV-3 is designed to supersede the MV-2 Valve.

SERVICE#	FIG.	MOUNTING HOLE	AUX. PORT	EXHAUST PORT	DELIVERY PORTS	TRUCK MANUF.	NOTES
800257	1	.27" Dia.	NONE	Push-to-Connect	Push-to-Connect		
800259	1	1/4" - 20 THD	NONE	Push-to-Connect	Push-to-Connect		
800515	1	M6 X 1-6H	NONE	Nipple	1/4" PT		
800516	1	.27" Dia.	NONE	Nipple	1/4" PT		
800517	3	M6 X 1-6H	NONE	1/8" PT male	1/4" PT		
800518	1	.27" Dia.	1/8" PT	Nipple	1/4" PT		
800519	1	1/4" - 20 THD	NONE	1/4" PT female	1/4" PT		
800521	2	1/4" - 20 THD	NONE	Nipple	1/4" PT		
800523	1	#10-24	NONE	Nipple	1/4" PT		
800529	1	1/4" - 20 THD	NONE	Nipple	Push-to-Connect		
800530	1	1/4" - 20 THD	NONE	Nipple	1/4" PT		
800573	1	1/4" - 20 THD	NONE	1/8" PT male	1/4" PT		
800584	1	M6 X 1-6H	1/8" PT	Nipple	1/4" PT		
800520	1	1/4" - 20 THD			1/4" PT		Navistar
800526	1	1/4" - 20 THD			1/4" PT		
800545	4	1/4" - 20 THD			1/4" PT		
800527	4	M6 X 1-6H			1/4" PT		Ford
065725	4	M6 X 1-6H			1/4" PT		
800258	4	M6 X 1-6H			Push-to-Connect		Ford
800525	1	.275"			1/4" PT		
800036	1	1/4" - 20 THD			1/4" PT		
800039	1	M5 X 8-0 - 6H			1/4" PT		Kenworth
800260	1	M5 X 8-0 - 6H			Push-to-Connect		
800353	1	#10 - 24			1/4" PT		
800522	1	M6 X 6 - 6H	1/8" - 27		1/4" PT		Mack
800528	1	#10 - 24			1/4" PT		
800531	3				1/4" PT		

MV-3 (suite)

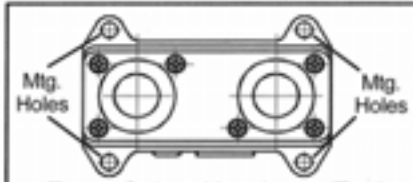

To Replace Part #	Order Service Part #	Mounting Hole	(Truck Manuf.)
065157 ...	800516	.275"	
065160 ...	800518	.275"	
065187 ...	800573	1/4-20	(Frtlnr.)
065523 ...	065523	.275"	
065697 ...	800516	.275"	
106331 ...	800516	.275"	
106992 ...	800516	.275"	
107212 ...	800518	.275"	
107433 ...	800573	1/4-20	
108155 ...	800516	.275"	
109391 ...	065523	.275"	
109392 ...	065523	.275"	
109865 ...	800516	.275"	
109935 ...	065523	.275"	
109985 ...	800516	.275"	
800082 ...	800520	1/4-20	(Nvstr.)
800257 ... 800257	.275"		
800516 ...	800516	.275"	
800518 ...	800518	.275"	
800520 ...	800520	1/4-20	(Nvstr.)
800526 ...	800526	1/4-20	
800573 ...	800573	1/4-20	(Frtlnr.)
5000628 .	800516	.275"	
5000884 .	800520	1/4-20	(Nvstr.)
5000893 .	800520	1/4-20	(Nvstr.)
5002715 . 800257	.275"		(Nvstr.)
5004872 . 800257	.275"		(Ptrblt.)
5005053 .	800516	.275"	
5005054 .	800516	.275"	
5005056 .	800518	.275"	
5005059 .	800573	1/4-20	(Frtlnr.)
5005067 .	800520	1/4-20	(Nvstr.)



To Replace Part #	Order Service Part #	Mounting Hole	(Truck Manuf.)
065192 ...	800521	1/4-20	(Ford)
065304 ...	800545	1/4-20	
065496 ...	800527	M6 x 1-6H	(Ford)
065725 ...	065725	M6 x 1-6H	
107467 ...	800521	1/4-20	(Ford)
108279 ...	800545	1/4-20	
109325 ...	800527	M6 x 1-6H	(Ford)
800258 ... 800258	M6 x 1-6H		(Ford)
800521 ...	800521	1/4-20	(Ford)
800527 ...	800527	M6 x 1-6H	(Ford)
800545 ...	800545	1/4-20	
5002695 . 800258	M6 x 1-6H		(Ford)
5004732 .	800545	1/4-20	
5005060 .	800521	1/4-20	(Ford)
5005063 .	800545	1/4-20	(Ford)
5005066 .	800527	M6 x 1-6H	(Ford)

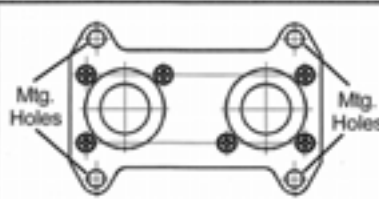

To Replace Part #	Order Service Part #	Mounting Hole	(Truck Manuf.)
065156 ...	800515	M6 x 1-6H	(Mack)
065186 ...	800519	1/4-20	
065208 ...	800584	M6 x 1-6H	(Mack)
065248 ...	800523	#10-24	(Ptrblt.)
065305 ...	800525	.275"	
106981 ...	800584	M6 x 1-6H	(Mack)
107215 ...	800525	.275"	
107218 ...	800515	M6 x 1-6H	(Mack)
107220 ...	800519	1/4-20	
107753 ...	800523	#10-24	(Ptrblt.)
131061 ...	065725	#10-24	
131062 ...	065725	#10-24	
800036 ...	800036	1/4-20	
800039 ...	800039	M5 x 8.0 - 6H	
800145 ...	800530	1/4-20	
800259 ... 800259	1/4-20		(Frtlnr.)
800260 ... 800260	M5x8.0-6H		(Kenw.)
800353 ...	800353	#10-24	
800515 ...	800515	M6 x 1-6H	(Mack)
800519 ...	800519	1/4-20 (Vlv., Wst. Str.)	
800522 ...	800522	M6 x 1-6H	(Mack)
800523 ...	800523	#10-24	(Ptrblt.)
800525 ...	800525	.365"	
800528 ...	800528	#10-24	
800530 ...	800530	1/4-20	
5000286 .	800519	1/4-20	
5000378 .	800036	1/4-20	
5000379 .	800036	1/4-20	
5000428 .	800039	M5 x 8.0 - 6H	
5000429 .	800039	M5 x 8.0 - 6H	
5001302 .	065725	#10-24	
5002197 .	800530	1/4-20	
5002205 .	800515	M6 x 1-6H	(Mack)
5002714 . 800260	M5 x 8.0-6H		(Kenw.)
5002716 . 800259	1/4-20		(Frtlnr.)
5002737 .	800039	M5 x 8.0 - 6H	
5002738 .	800039	M5 x 8.0 - 6H	
5003585 . 800259	1/4-20		(Frtlnr.)
5003682 . 800353	#10-24		(Ptrblt.)
5005051 .	800515	M6 x 1-6H	(Mack)
5005052 .	800515	M6 x 1-6H	(Mack)
5005057 .	800519	1/4-20	(Vlv.)
5005058 .	800519	1/4-20	(Wst. Str.)
5005062 .	800523	#10-24	(Ptrblt.)
5005064 .	800525	.275"	(Kenw.)
5005069 .	800530	1/4-20	
5005068 .	800529	1/4-20	(Frtlnr.)
5005646 .	800584	M6 x 1-6H	



To Replace Part #	Order Service Part #	Mounting Hole
800482 ...	800531	.285"
800531 ...	800531	.285"
5004587 .	800531	.285"
5005070 .	800531	.285"

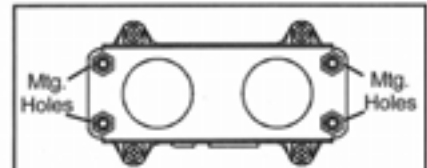

To Replace Part #	Order Service Part #	Mounting Hole	(Truck Manuf.)
065159 ...	800517	M6 x 1-6H	(Kenw.)
065379 ...	800517	M6 x 1-6H	(Kenw.)
107214 ...	800517	M6 x 1-6H	(Kenw.)
108825 ...	800517	M6 x 1-6H	(Kenw.)
800517 ...	800517	M6 x 1-6H	(Kenw.)
800553 ...	800553	#10-24	
5005055 .	800517	M6 x 1-6H	(Kenw.)
5005644 .	800517	M6 x 1-6H	(Kenw.)

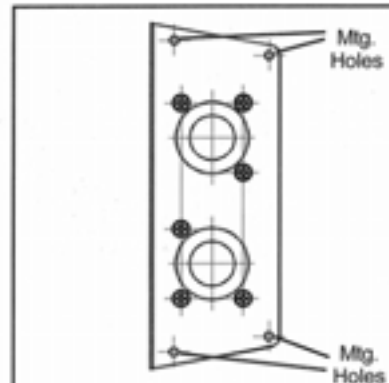

To Replace Part #	Order Service Part #	Mounting Hole
800087 ...	800259	.200"
800529 ...	800259	.200"
5000815 .	800259	.200"
5000819 .	800259	.200"
5005068 .	800529	.200"

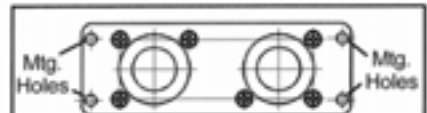

To Replace Part #	Order Service Part #	Mounting Hole	(Truck Manuf.)
800445 .	800445	.270"	
5004463 .	800445	.270"	(Mack)

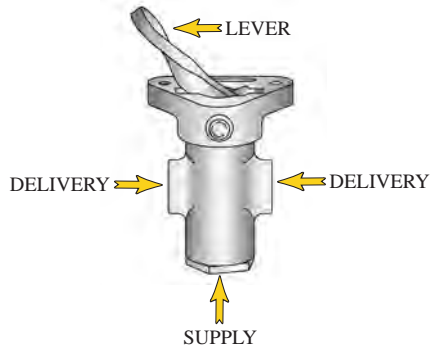

- **TW-1 Control Valve.**
- Lever type.
- Manually operated valve.
- Weight .5 lbs.

SERVICE#	SUPPLY	DELIVERY	EXHAUST	NOTES
228729	1/8" PT	2-1/8" PT	-	Two Position Controls, Zinc - Chrome
229635	1/8" PT	2-1/8" PT	-	Two Position Controls, Steel - Chrome
277516	1/8" PT	2-1/8" PT	-	Two Position Controls, Nylon - Black



- **Tw2 & TH-3 Control Valve.**
- TW-2 (280905N) 2 lever positions.
- TH-3 (280904N) 3 lever positions.
- TH-3 (281560N) 3 lever positions.
- Lever Operated Control Valve.
- To control parking and emergency brakes.

SERVICE#	SUPPLY	DELIVERY	LEVER	NOTES
280904N	1/8" PT	2-1/8" PT	Centering	
280905N	1/8" PT	2-1/8" PT	Centering	
281560N	1/8" PT	2-1/8" PT	Positioning	

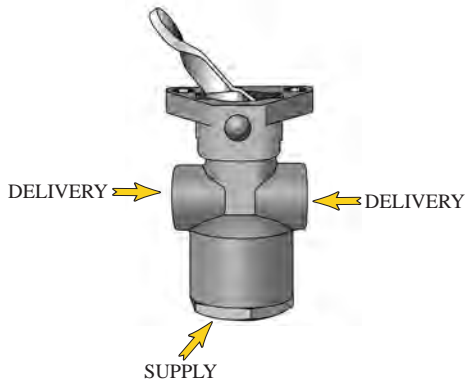

- **TW-3 Emergency Control Valves.**
- Lever type.
- Used in conjunction with parking and emergency brake systems.
- Weight .6 lbs.

SERVICE#	SUPPLY	DELIVERY	EXHAUST	NOTES
225892	1/4" PT	2-1/4" PT	-	Vacuum control. Two Position Controls
228762	1/4" PT	2-1/4" PT	-	Vacuum control. Two Position Controls
283040	1/4" PT	2-1/4" PT	-	Two Position Controls
283935	1/4" PT	2-1/4" PT	-	Two Position Controls

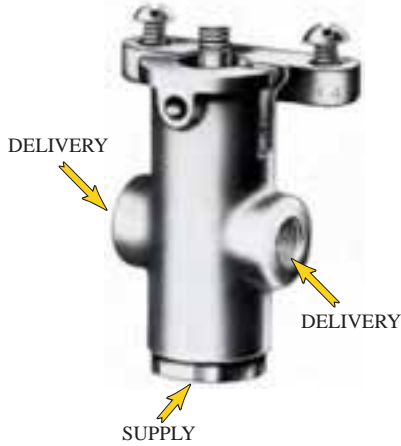

- TW-4 Push Button Control Valve.
- Commonly used with air starter systems.
- Button not included.

SERVICE#	SUPPLY	DELIVERY	CONTROL	RESERVOIR	CRACK PRESSURE	NOTES
276635	1/8" PT	2-1/8" PT				

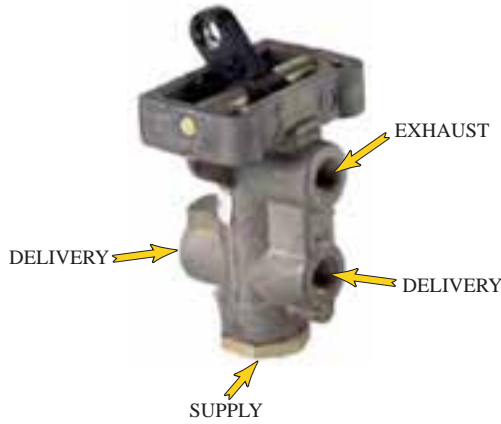

- TW-11 Control Valve.
- Used in conjunction with the HR-1 Hydraulic Relay Valve.

SERVICE#	SUPPLY	DELIVERY	EXHAUST	NOTES
065316	1/8" PT	2-1/8" PT	1/8" PT	
065356	1/8" PT	2-1/8" PT	1/8" PT	

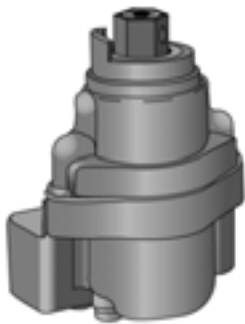

- TC-2 Trailer Control Hand Valve.
- Steering column mount.
- Generally used on tractors and provides modulated control on trailer brakes only.
- Weight 2.2 lbs.

SERVICE#	SUPPLY	DELIVERY	EXHAUST	GRAD. RANGE PRESSURE	FINAL DELIVERY PRESSURE	NOTES
101460	1/4" PT	1/4" PT	1/4" PT	5 - 125 PSI	125 PSI	
276270	1/4" PT	1/4" PT	1/4" PT	5 - 80 PSI	RÉSERVOIR	
800172	1/4" PT	1/4" PT	1/4" PT	5 - 125 PSI	RÉSERVOIR	
800173	1/4" PT	1/4" PT	1/4" PT	5 - 80 PSI	80	

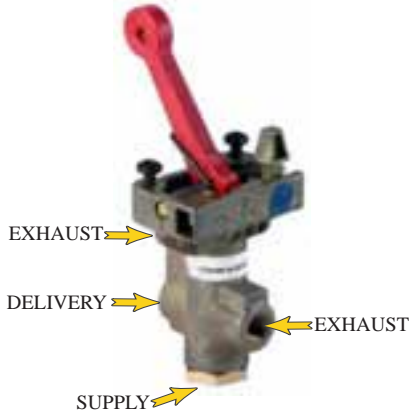

- **TC-4 Modulating Control Valve.**
- The TC series brake valves are hand operated modulating control valves. The TC valves are capable of almost infinite graduation of pressure between approximately 5 PSI and their individual maximum delivery settings. The TC-4 control valve is generally used to modulate parking and emergency brakes.
- Weight 0.73 lbs.

SERVICE#	SUPPLY	DELIVERY	EXHAUST	LOCKING BUTTON POSITION	DELIVERY PRESSURE	NOTES
282368	1/8" PT	2-1/8" PT	2-1/8" PT	LEFT	86-100 PSI	-
282382N	1/8" PT	2-1/8" PT	2-1/8" PT	LEFT	86-100 PSI	-



- **TC-6 Trailer Control Valve.**

SERVICE#	SUPPLY	DELIVERY	EXHAUST	FINAL DELIVERY PRESSURE	NOTES
065512	1-1/4" PT	1-1/4" PT	1-1/4" PT	85 PSI	
101786	1-1/4" PT	1-1/4" PT	1-1/4" PT	120 PSI	
106385	1-1/4" PT	1-1/4" PT	1-1/4" PT	85 PSI	
289884	1-1/4" PT	1-1/4" PT	1-1/4" PT	120 PSI	
289885	1-1/4" PT	1-1/4" PT	1-1/4" PT	50 PSI	
5003601	1-1/4" PT	1-1/4" PT	1-1/4" PT	85 PSI	



- **TC-7 Trailer Control Valve.**

SERVICE#	SUPPLY	DELIVERY	EXHAUST	FINAL DELIVERY PRESSURE	NOTES
101860	1-1/4" PT	1-1/4" PT	1-1/4" PT	RESERVOIR	POSITIONING
102394	1-1/4" PT	1-1/4" PT	1-1/4" PT	RESERVOIR	SELF RETURNING
102707	1-1/4" PT	1-1/4" PT	1-1/4" PT	80 PSI	POSITIONING
108233	1-1/4" PT	1-1/4" PT	1-1/4" PT	80 PSI	SELF RETURNING
800960	1-3/8" PTC	1-3/8" PTC	1-3/8" PTC	RESERVOIR	POSITIONING
802672	1-3/8" PTC	1-3/8" PTC	1-3/8" PTC	RESERVOIR	SELF RETURNING



• TCS-9000 Trailer Control Valve.

SERVICE#	SUPPLY	DELIVERY	EXHAUST	NOTES
802033	3/8" PTC	3/8" PTC	1/4" PTC	

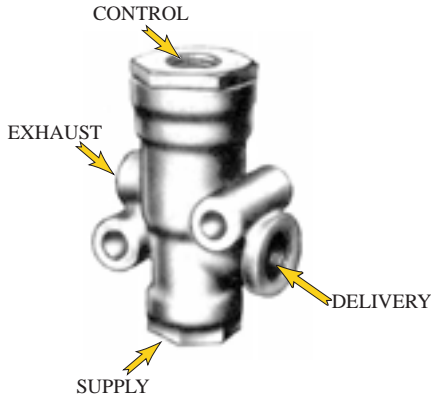

- **SS-1 Shut-Off Valve**
- The SS-1 shut-off valve is an air operated on-off valve and is non-exhausting. The valve may be remotely mounted and opened and closed using air pressure. The SS-1 is similar in operation to an air starter valve except that it is lower in capacity.
- With common pressure at ports 1 and P3 inlet opens at “A” psi & closes at “B” psi.
- Weight 6 lbs.

SERVICE#	SUPPLY	DELIVERY	CONTROL	EXHAUST	PORT DESIGNATIONS				“A” P.S.I. APPROX.	“B” P.S.I. APPROX.
					P1	P2	P3	P4		
278824	1/4” PT	1/4” PT	1/4” PT	1/8” PT	CONTROL	VENT	SUPPLY	DELIVERY	42	31
279163	1/4” PT				EMERGENCY RESERVOIR	VENT	AUXILIARY DIAPHRAGM	HAND BRAKE DELIVERY	65	53
284181 (1)	1/4” PT				CONTROL	VENT	SUPPLY	DELIVERY	42	31

(1) Add Check Valve #284352 in P2

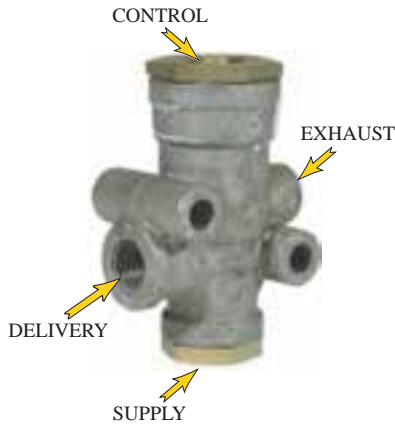

- **SV-1 Synchronizing Valve.**
- The synchro valve is pilot operated, non-graduating, pneumatic control valve. These valves are used to control air from a remote supply which is different than control air supply. They have definite opening and closing pressures and can be used to delay or sequence the action of other pneumatic devices.
- Weight 6 lbs.

SERVICE#	SUPPLY	DELIVERY	CONTROL	EXHAUST	INLET OPENS AT	EXHAUST OPENS AT	NOTES
278825	1/4” PT	1/4” PT	1/4” PT	1/8” PT	42	28	
281262	1/4” PT	1/4” PT	1/4” PT	1/8” PT	75	60	
282472	1/4” PT	1/4” PT	1/4” PT	1/8” PT	21	11	
283700 *	1/4” PT	1/4” PT	1/4” PT	1/8” PT	62	50	
284949 *	1/4” PT	1/4” PT	1/4” PT	1/8” PT	42	28	
287635 *	1/4” PT	1/4” PT	1/4” PT	1/8” PT	75	60	
288253 *	1/4” PT	1/4” PT	1/4” PT	1/8” PT	21	11	
288671	1/4” PT	1/4” PT	1/4” PT	1/8” PT	86	75	

* Add Breather Valve #222797 in Exhaust Port

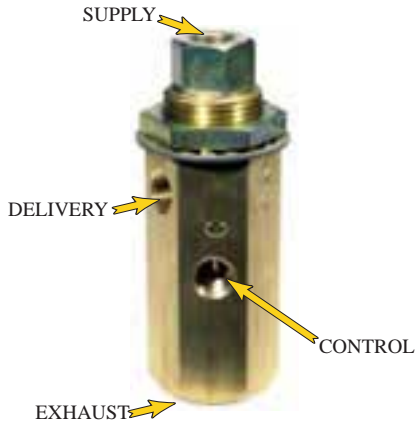

- **TR-2 Inversion Valve.**
- With 125 psi supply pressure, valve must begin to exhaust at 65 PSI nominal ascending control pressure.
- Valve must deliver full supply pressure with 40 psi nominal descending control pressure.

SERVICE#	SUPPLY	DELIVERY	CONTROL	NOTES
277340	1/4" PT	2-1/4" PT	3-1/4" PT	

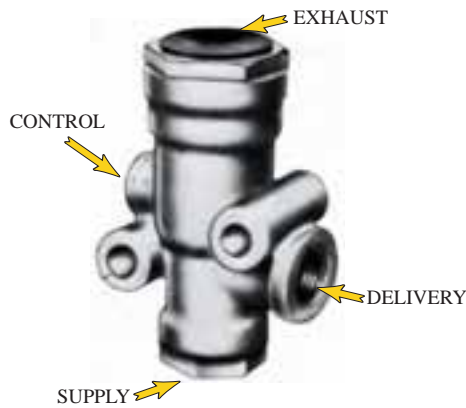

- **TR-3 Inversion Valve.**
- With common control & supply pressure, inlet opens at "A" PSI descending pressure and exhaust opens at "B" PSI ascending pressure.

SERVICE#	SUPPLY	DELIVERY	CONTROL	INLET OPENS AT "A"	EXHAUST OPENS AT "B"	NOTES
101450	1/4" PT	1/4" PT	1/8" PT	25	40	Special Duty-Bus Application
280758	1/4" PT	1/4" PT	1/8" PT	45	60	
281318	1/4" PT	1/4" PT	1/8" PT	35	70	
281459	1/4" PT	1/4" PT	1/8" PT	25	40	
288586	1/4" PT	1/4" PT	1/8" PT	75	90	

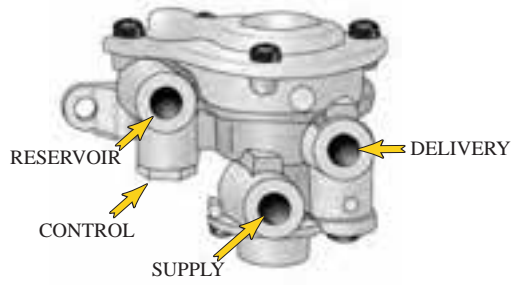

- **SR-1 Spring Brake Valve.**
- Used on trucks and tractors with dual air brake systems.
- Spring brake release pressure is limited to 90-95 PSI through the SR-1.
- Normal parking functions are controlled through the SR-1.
- Weight 1.7 lbs.

SERVICE#	SUPPLY	DELIVERY	RESERVOIR	CONTROL	NOTES
286364	1/4" PT	1/4" PT	1/4" PT	1/4" PT	Reservoir Trip Pressure - 55 PSI
288063	1/4" PT	1/4" PT	1/4" PT	1/4" PT	Reservoir Trip Pressure - 30 PSI

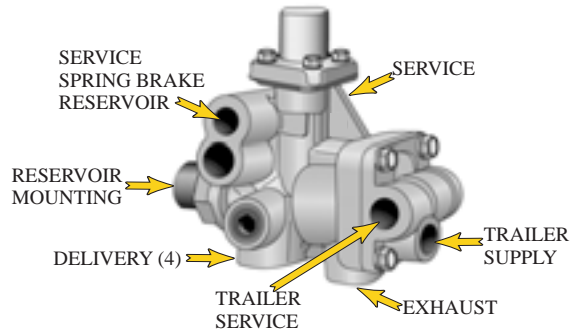

- **SR-2 Valve.**
- Used on trailers with dual air brake systems.
- Ability to release the spring brakes at least once prior to their application.
- Weight 2.6 lbs.

SERVICE#	TRAILER SUPPLY	DELIVERY	RESERVOIR	SERVICE RESERVOIR	TRAILER SERVICE	EXHAUST	NOTES
102761	1/4" PT	4-3/8" PT	3/4" PT	2-1/4" PT	1/4" PT	3/8" PT	-
103061	1/4" PT	4-3/8" PT	1/2" PT	2-1/4" PT	1/4" PT	3/8" PT	-
287376	1/4" PT	4-3/8" PT	3/4" PT	1-1/4" PT	1/4" PT	3/8" PT	Does not have a trailer service port for anti-compounding
288497	1/4" PT	4-3/8" PT	1/2" PT	2-1/4" PT	1/4" PT	3/8" PT	No anti-compound

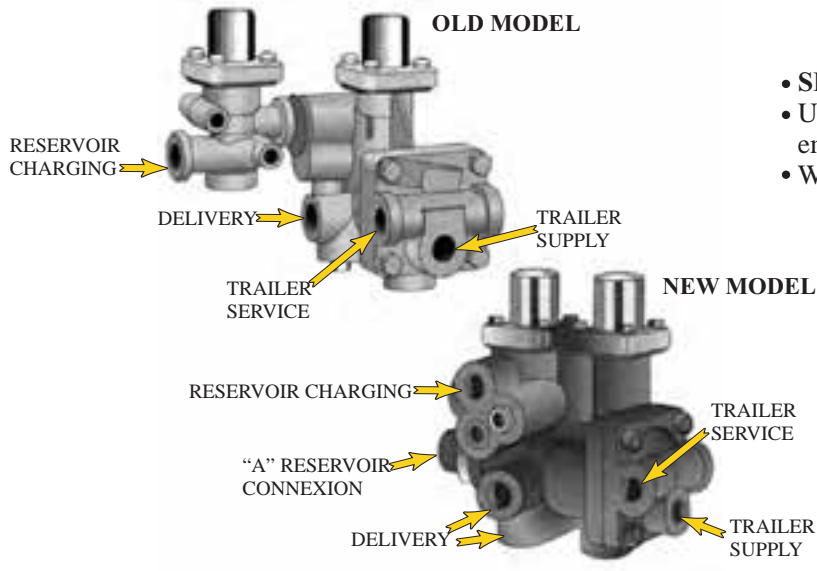

- **SR-4 Spring Brake Valve.**
- Used on trailers to control both parking and emergency brake functions.
- Weight 3.5 lbs.

SERVICE#	TRAILER SUPPLY	DELIVERY	"A" MALE RESERVOIR	TRAILER SERVICE	RESERVOIR CHARGING	NOTES
101112	1/4" PT	4-3/8" PT	3/4" PT	1/4" PT	2-1/4" PT	Reservoir Male Connector Port - 3/4" PT
101622	1/4" PT	4-3/8" PT	1/2" PT	1/4" PT	2-1/4" PT	Reservoir Male Connector Port - 1/2" PT
107539	1/4" PT	4-3/8" PT	3/4" PT	1/4" PT	2-1/4" PT	New Configuration, interchangeable with 101112 and 101622
108076	1/4" PT	4-3/8" PT	1/2" PT	1/4" PT	2-1/4" PT	New Configuration, interchangeable with 101112 and 101622

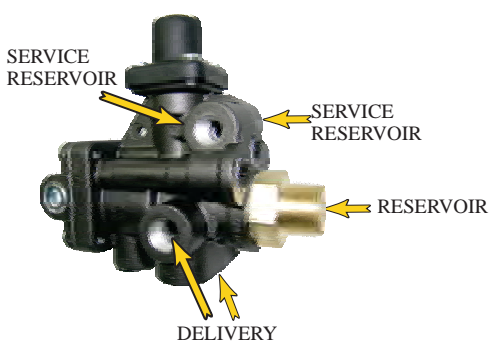

- **SR-5 Valve.**
- Used on trailers with dual air brake systems.
- Permits the use of a single reservoir on the trailer.
- Weight 3 lbs.

SERVICE#	TRAILER SUPPLY	DELIVERY	RESERVOIR	SERVICE	NOTES
065437	1/4" PT	4-3/8" PT	3/4" PT	3-1/4" PT	With Anti-Compounding
065438	1/4" PT	4-3/8" PT	3/4" PT	3-1/4" PT	w/o Anti-Compounding
065439	1/4" PT	4-3/8" PT	1/2" PT	3-1/4" PT	With Anti-Compounding
065440	1/4" PT	4-3/8" PT	1/2" PT	3-1/4" PT	w/o Anti-Compounding



• SR-7 Trailer Spring Brake Valve.

SERVICE#	SERVICE# NEW	SUPPLY	DELIVERY	CONTROL PORT		BALANCE PORT		PARK CONTROL
				SIZE	FITTING	SIZE	FITTING	
801328	K021557	1/2"NPT	4-3/8"NPT	1/4"NPT	-	1/4"NPT	-	1/4"NPT
801329	K021558	1/2"NPT	4-3/8"NPT	3/8"PTC	STRAIGHT	3/8"PTC	STRAIGHT	1/4"NPT
801536	K021559	1/2"NPT	4-3/8"NPT	3/8"PTC	90°	3/8"PTC	STRAIGHT	1/4"NPT
801569	K021560	1/2"NPT	4-3/8"NPT	3/8"PTC	90°	3/8"PTC	90°	1/4"NPT
	K021562	1/2"NPT	4-3/8"NPT	1/4"NPT	-	1/4"NPT	-	1/4"NPT
	K021563	1/2"NPT	4-3/8"NPT	3/8"PTC	STRAIGHT	3/8"PTC	STRAIGHT	1/4"NPT

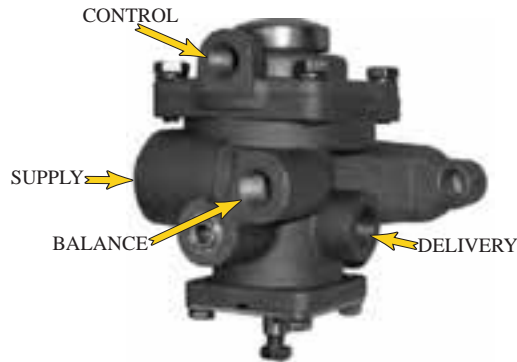

• R-7 Modulating Relay Valve.

- Will modulate the spring brakes through application of the foot valve if rear axle service brake pressure is lost.
- 2 port delivery.
- Weight 2.5 lbs.

SERVICE#	SUPPLY	DELIVERY	CONTROL	BALANCE	RELEASE PRESSURE	NOTES
103081	3/8" PT	2-3/8" PT	1/4" PT	1/4" PT	95 PSI	
283932	3/8" PT	2-3/8" PT	1/4" PT	1/4" PT	85 PSI	



- DS-1 Double Check Valve.
- Stoplight switch.
- Functions as both a stoplight switch and a double Check Valve.
- Weight 1 lb.

SERVICE#	MALE PORT "A"	FEMALE PORT "B"	FEMALE PORT "C"	FEMALE PORT "D"	NOTES
228050	1/2" PT	1/4" PT	1/4" PT	-	#8-32 Terminal Thread, OE #276374
228165	3/8" PT	1/4" PT	1/4" PT	-	#8-32 Terminal Thread
228520	1/2" PT	3/8" PT	1/4" PT	-	#8-32 Terminal Thread, OE #276376
229493	1/2" PT	1/4" PT	1/4" PT	1/4" PT	#8-32 Terminal Thread
275153	1/2" PT	3/8" PT	1/4" PT	-	#8-32 Terminal Thread



- DS-2 Combined Stop Light Switch & Double Check Valve.
 - Contacts close AT 4 PSI ascending-pressure
- It operates in conjunction with the brake valve or hand control valve by completing the stop light electrical circuit and by directing the flow of air pressure into a common outlet line from either of the two inlet lines.

SERVICE#	O.E PART #	MALE PORT "A"	FEMALE PORT "B"	FEMALE PORT "C"	FEMALE PORT "D"	"E" TERMINAL THREAD
104563	104563	3/8" PT	3/8" PT	1/4" PT	-	#8-32
286416	286416	3/8" PT	1/4" PT	1/4" PT	-	#8-32
286445	286445	-	3/8" PT	3/8" PT	3/8" PT	#8-32
286448	286448	1/2" PT	3/8" PT	1/4" PT	-	#10-32
286450	286450	3/8" PT	3/8" PT	1/4" PT	-	#10-32
286452	286452	3/8" PT	3/8" PT	3/8" PT	-	#8-32
286453	286453	3/8" PT	3/8" PT	3/8" PT	-	#10-32
286704	286704	-	3/8" PT	3/8" PT	3/8" PT	#10-32
286704	287287	-	3/8" PT	3/8" PT	3/8" PT	#10-32
286453	287372	3/8" PT	3/8" PT	3/8" PT	-	#10-32



- TE-1 Trailer Emergency Stop Light Switch.
- Circuit between terminals to be closed from 60 psi to 0 psi.
- The Trailer Emergency Stop Light Switch is an electra-pneumatic switch and lights the trailer stop lights if pressure in the tractor emergency line is reduced to approximately 60 psi for any reason.

SERVICE#	AIR SUPPLY	TERMINAL	NOTES
228477	1/8" PT	8-32 THRD	



- **SL-3 Stop Light Switch.**
- The Stop Light Switch is an Electra-Pneumatic switch. Operating in conjunction with the vehicle stop lights and service brake valve, it completes an electrical circuit each time a brake application is made.
- Weight 0.5 lbs.

SERVICE#	SUPPLY	TERMINAL THREAD SIZE	NOTES
226262	1/4" PT	10-32	
226411	1/4" PT	10-32	
227699	1/4" PT	10-32	

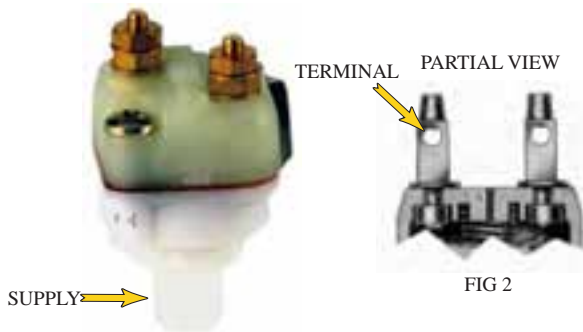

- **SL-4 Stop Light Switch.**
- The Stop Light Switch is an Electra-Pneumatic switch. Operating in conjunction with the vehicle stop lights and service brake valve, it completes an electrical circuit each time a brake application is made.
- Weight 0.5 lbs

SERVICE#	FIG #	PIPE THREAD SUPPLY	TERMINAL THREAD SIZE	NOTES
228600	1	1/4" PT	8-32	
228687	1	3/8" PT	8-32	
228688	2	1/4" PT	-	



- **SL-5 Stop Light Switch**
- The Stop Light Switch is an Electra-Pneumatic switch. Operating in conjunction with the vehicle stop lights and service brake valve, it completes an electrical circuit each time a brake application is made.
- Weight 0.4 lbs.

SERVICE#	FIG.	SUPPLY	TERMINAL THD SIZE	NOTES
101417	1	1/4" PT	#10-32	Ford
101967	2	1/4" PT	#8-32	Same as 286392 with Reducer
102601	1	1/4" PT	#8-32	-
103165	1	1/4" PT	#8-32	-
104057	-	1/4" PT	#10-32	-
104748	1	1/4" PT	#10-32	-
107586	-	1/4" PT	#10-32	Volvo
286392	-	1/4" PT	#8-32	-
286404	-	1/4" PT	#10-32	-
287416	-	1/4" PT	#8-32	-
287624	-	1/4" PT	#10-32	Kenworth
289285	1	1/4" PT	#10-32	Mack

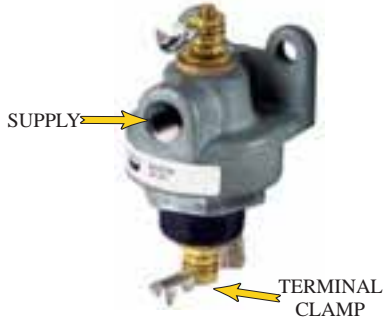

- **LP-2 Low Pressure Indicator.**
- The LP-2 and 3 Low Pressure Indicators are pressure sensitive, electric-pneumatic switches that are designed to give an automatic warning to the driver in the event air pressure in the service brake system is below a safe minimum for normal operations. The low pressure indicator generally activates a dash mounted light and buzzer.
- Weight 0.7 lbs.

SERVICE#	SUPPLY	CUT-OUT PRESSURE	TERMINAL CLAMP	NOTES
101803	1/4" PT	57 - 69 PSI	YES	
223578	1/4" PT	60 - 65 PSI	YES	
223870	1/4" PT	60 - 65 PSI	NO	
224044	1/4" PT	64 - 76 PSI	NO	W/O CABLE TERMINAL
288408	1/4" PT	54 - 66 PSI	NO	WATHERPROOF



- **LP-3 Low Pressure Indicator.**
- The LP-2 and 3 Low Pressure Indicators are pressure sensitive, electric-pneumatic switches that are designed to give an automatic warning to the driver in the event air pressure in the service brake system is below a safe minimum for normal operations. The low pressure indicator generally activates a dash mounted light and buzzer.
- Weight 0.13 lbs

SINGLE TERMINAL

SERVICE#	"A"	CUT-OUT PRESSURE	NOTES
104246	1/4" PT	66 ± 6	Push on terminal
279416	1/4" PT	60 ± 6	
279472	1/4" PT	75 ± 6	
280530	1/4" PT	70 ± 6	
289397	1/8" PT	75 ± 6	

DOUBLE TERMINAL

SERVICE#	"A"	CUT-OUT PRESSURE	NOTES
228750	1/4" PT	60 ± 6	
275083	1/4" PT		
276599	1/4" PT	30 ± 3	
277155	1/4" PT	50 ± 5	
280743	1/4" PT	60 ± 6	W/O CABLE TERMINAL
283029	1/4" PT	60 ± 6	W/O CABLE TERMINAL
284793	1/4" PT	80 ± 6	W/O CABLE TERMINAL
284833	1/4" PT	70 ± 6	W/O CABLE TERMINAL
288522	1/4" PT	66 ± 6	W/O CABLE TERMINAL

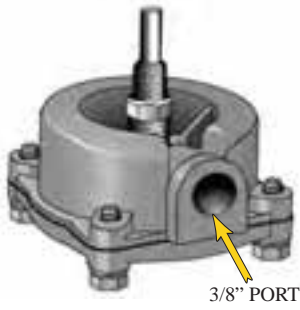

- **DV-2 Automatic Drain Valve.**
- Mounts into bottom drain port of the reservoir.
- Only one moving part.
- Weight .9 lbs.

SERVICE#	PORT	NOTES
281923	3/8" PT	Non-Heated
281924	3/8" PT	
284412	3/8" PT	With Heated
284795	3/8" PT	With Heated